

Jabil Software Services (JSS)



Embedded
Systems

Web &
Mobile

IoT

Cloud



Wireless
Networking



Wireline
Networking



CASE STUDY

Jabil RF Reference Platform

JABIL

Customer Needs

Jabil's *Communications, Cloud & Compute (CCC)* division within the EMS segment serves customers requiring a broad range of communication, computing, cloud, and storage solutions. The CCC division designs and manufactures server platforms, storage platforms, RF solutions, switches, routers, optical solutions, and photonics solutions.

Jabil required a reference platform to facilitate the rapid development of Remote Radio Unit (RRU) wireless transceivers, used to convert from wireless to wireline communications. RRU's contain RF circuitry for the base station, analog to digital converters, up/down converters, optical interfaces, and local processing capabilities.

The RF Reference Platform permits Jabil to quickly configure client-specific solutions with a minimum of rework, overhead and cost. Leveraging this platform allows Jabil's customers to rapidly address evolving radio telecommunication technologies (including the provision of advanced 5G communication solutions), and to significantly reduce time-to-market and time-to-revenue. It allows customers to respond more rapidly to evolving markets and to reduce the duration of product development lifecycles.

Scope

JSS was engaged by Jabil CCC to develop the embedded software necessary to maintain, calibrate and control the RRU radio hardware for the RF Reference Platform. Other goals included achieving:

- Improved data transfer rates via real-time system management (compared with simple hardware presets).
- Lower power losses due to smart power management.
- Rapid responses to error conditions to ensure safety (such as overheating or hardware malfunction).

JSS was responsible for architecting, designing, and implementing the embedded components of the reference platform, including:

- Full ownership of all software running on the embedded processor, including the build environment, Linux kernel, BSP, control logic, and communication with the controller (DU).
- O-RAN compliance, including:
 - NETCONF-YANG based interface to the clients (DU, EMS)
 - eCPRI fronthaul
 - PTP/SYNCE based timing
- Management interfaces (via CPRI).
- Radio hardware configuration, control, and monitoring.
- Application monitoring.
- Middleware (messaging, IPC, RPC, synchronization).

- Hardware abstraction.

JSS was also responsible for CI/CD and automated testing, including unit testing, integration testing and system testing.

The following image demonstrates the high-level functions of the RRU:

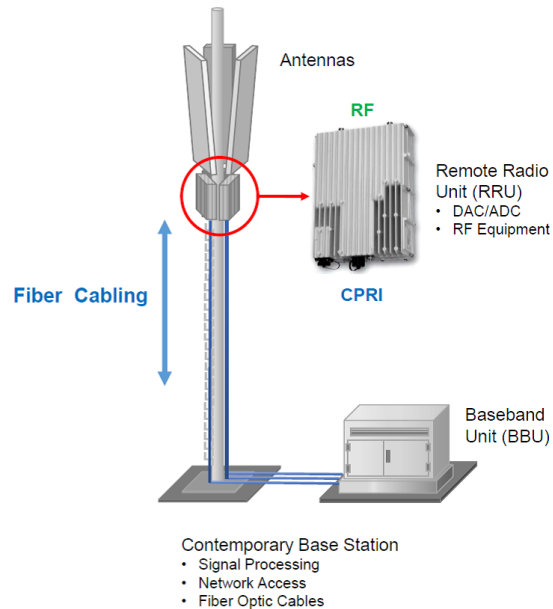

The embedded software is fully event driven, leveraging a carefully architected range of independent modules for distinct functions, including configurable abstraction layers to interface with all hardware components. The abstraction layers facilitate reusability of all core functionality and the rapid porting of the software solution to different hardware platforms. A single codebase is leveraged for multiple radios and the software is fully run-time configurable, including real-time hardware detection and software configuration. Configuration data is kept separate from executable components, facilitating easier updates and testing. A hardware block diagram is shown below:

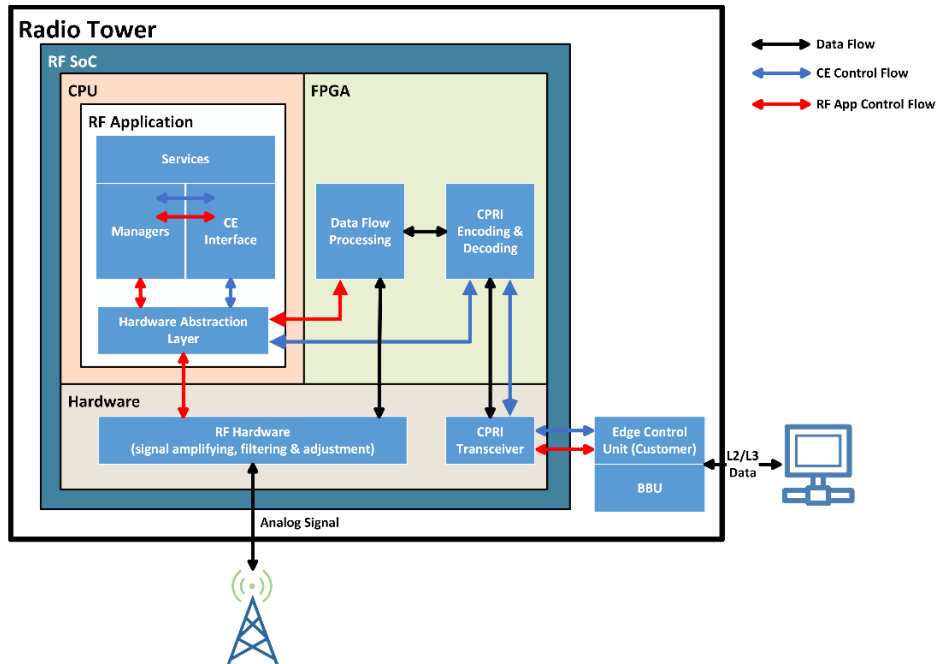

A software block diagram is shown below:

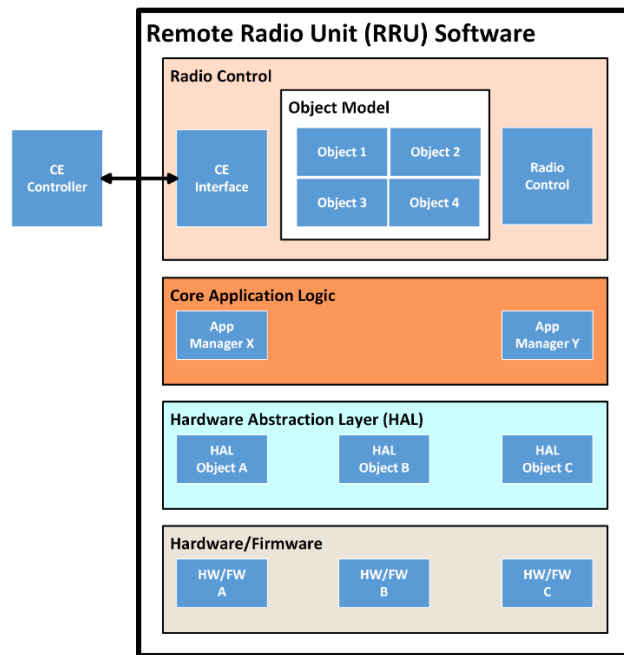

The "CE Interface" is updated whenever adapting to a new "CE Controller" and the Hardware Abstraction Layer is updated when porting to new hardware.

JSS dedicated a team of 15 staff to developing the RF Reference Platform, including architects, embedded developers, and testers. Technologies used for the development included C/C++, Python, RPC, CLI, event-driven approaches, JSON-based external interfaces, Netconf-based external interfaces, ORAN, Bitbake, Petalinux, Uboot & FSBL.

Deliverables

JSS delivered a fully tested embedded codebase for the RRU, along with comprehensive documentation. Following are some capabilities which JSS applied as part of delivering this project:

- Radio management (including power, current and gain).
- Xilinx DPD module configuration for radio management logic.
- Controlling power amplifiers, including calibration, biasing, and correction of PA parameters based on frequency and transistor temperature.
- Gain control algorithms (open-loop and closed-loop).

The solution was designed and built to facilitate optimal reusability, with:

- Run-time data-driven configuration.
- Hardware changes isolated from software logic/algorithms.
- Porting to a new RU platform possible within a matter of weeks.
- Self-configuring code based on hardware type and configuration files.
- \cong 90% code reuse.

The RF Reference Platform was developed by JSS leveraging an Agile methodology across several sprints. JSS and Jabil CCC clearly agreed scope and schedule expectations, and JSS leveraged a formal project management methodology to ensure efficient delivery.

Strategic Value

The RF Reference Platform provides Jabil with an easily configurable and extensible platform to facilitate the development of RRU's for the distinct hardware solutions of a varying range of customers. This approach permits Jabil to deliver customer solutions in a more rapid and cost-effective manner.

“The relationship established between JSS and Jabil CCC has been very positive for us. We are very happy with the work undertaken by JSS, and particularly with the willingness of the JSS team to engage in new and challenging fields. We plan to undertake further work with JSS over the coming years on other radio management projects.”

James Pelech, Jabil CCC System Architect

About Communications, Cloud & Compute (CCC)

Jabil's *Communications, Cloud & Compute (CCC)* division within the EMS segment serves customers requiring a broad range of communication, computing, cloud, and storage solutions. The CCC division designs and manufactures server platforms, storage platforms, RF solutions, switches, routers, optical solutions, and photonics solutions. Jabil CCC is a well-established leader in the provision of such solutions to Tier 1 worldwide customers.

About Jabil Software Services (JSS)

Jabil Software Services (JSS) delivers a broad range of advanced software services across several industries, leveraging an experienced team of architects, software developers and quality assurance engineers. JSS specializes in the efficient development of embedded systems, web & mobile apps, IoT solutions, cloud solutions, and networking solutions (wireless/wireline).