

JABIL CUTTING TOOLS

**Made for Professionals
by Professionals**

As demand for quality precision tools pave the way for more advanced innovations, Jabil Cutting Tools offer specialized carbide cutting tools for the discerning professional. We offer quality at a competitive price supported by best-in-class service, capabilities, expertise and scale.



OTHER SERIES

	ITEM	Mill Dia.		Page
		(Min)	(Max)	
	Carbide Drill BIT - with Uniform Diameter - Long Flute Type	1.1	13	90~91
	Carbide Drill BIT - with Uniform Diameter	1	7.7	92~93
	Carbide Drill BIT - with Uniform Diameter	7.8	14	94~95
	Carbide Drill BIT - with Stepped Shank	1	6	96~97
	Carbide Drill BIT - with Extended Neck - Long Flute Type	1.5	8.2	98~100
	Carbide Drill BIT - with Extended Neck - Long Flute Type	8.3	12	101~102
	Carbide Drill BIT - with Uniform Diameter - Left Hand	1	3.18	103~104
	Carbide Drill BIT - with Uniform Diameter - Left Hand	3.2	6.5	105
	Carbide Drill BIT - Miniature - 1/8" Shank	0.2	3.175	106~107
	Carbide Position Drill - Helix	2	12	108
	Carbide Position Drill - Flat Tip - Right Hand - Double Heads	3	6	109
	Carbide Position Drill - Pyramid - Tip	4	4	109
	Carbide Center Drill - Double Heads	1	5	110
	Carbide Twist Drill - Internal Coolant Hole - 3xD	3	7.5	111~112
	Carbide Twist Drill - Internal Coolant Hole - 3xD	7.6	12	113~114
	Carbide Twist Drill - Internal Coolant Hole - 5xD	3	7.5	115~116
	Carbide Twist Drill - Internal Coolant Hole - 5xD	7.6	12	117~118
	Carbide Twist Drill - Internal Coolant Hole - 8xD	3	7.5	119~120
	Carbide Twist Drill - Internal Coolant Hole - 8xD	7.6	12	121~122

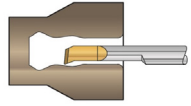

Carbide Miniature Boring - Front Boring for Easy Cutting

1

8

123

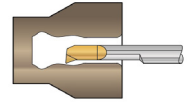

Carbide Miniature Boring - Front Boring for Heavy Cutting

1

8

123

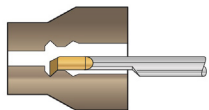

Carbide Miniature Boring - Front Boring 45° Back - Chamfer Angle

1

8

124

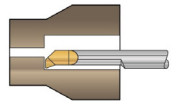

Carbide Miniature Boring - Front Boring 90°

1

8

124

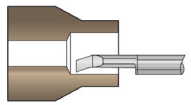

Carbide Miniature Boring - Front Boring for Copper

1

6

125

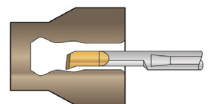

Carbide Miniature Boring - Front Boring 45° Back - Chamfer Angle for Copper

1

6

125

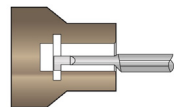

Carbide Miniature Boring - Grooving

1

6

126

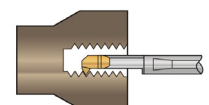

Carbide Front End Fastening - Front Boring - Threading

2.4

6

127

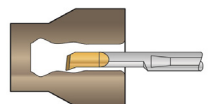

Carbide Front End Fastening - Front Boring - for Easy Cutting

1

8

128

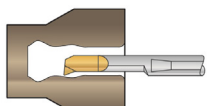

Carbide Front End Fastening - Front Boring - for Heavy Cutting

1

8

128

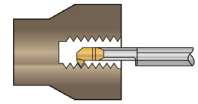

Carbide Miniature Boring - Treading

2.4

6

129

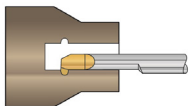

Carbide Miniature Boring - Grooving R Type

4

6

129

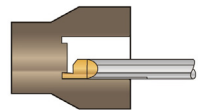

Carbide Miniature Boring - Slotting

4

8

130

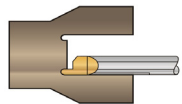

Carbide Miniature Boring - Slotting - R Type

4

6

130

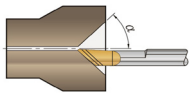

Carbide Chamfer

15

15

131

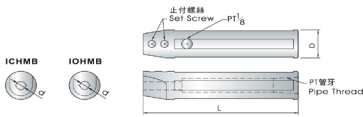

Miniture Boring Holder - Internal Coolant Hole

3

10

132-133



Tool Holder - Internal Coolant Hole for Machining on Back Side

3

8

134

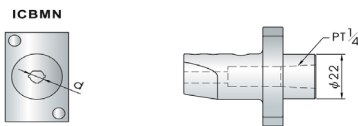

Carbide Reamer - Standard

1

4.6

135-136



Carbide Reamer - Standard

4.7

8.3

137-138



Carbide Reamer - Standard

8.4

13

139-140



Carbide Reamer - Long Shank

3

20

141



Carbide Threading 60°

1.05

1.5

142

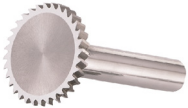

Carbide T Shape Milling - Straight Flute

15

30

143

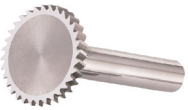

Carbide Shape Milling - Helix Flute

15

30

144



Carbide End Mill - Slim Shank
(Solid Type. Non-Brazed)

5

25

145



Carbide Circular Saw Blade -
Small Inner Diameter

15

15

146

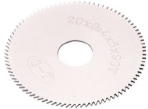

Carbide Circular Saw Blade -
Small Inner Diameter

20

20

147



Carbide Circular Saw Blade -
Small Inner Diameter

20

20

148



Carbide Circular Saw Blade - S
mall Inner Diameter

25

25

149



Carbide Circular Saw Blade -
Small Inner Diameter

30

30

150



Carbide Circular Saw Blade -
Small Inner Diameter

45

45

151



Carbide Circular Saw Blade -
for Beryllium Copper

20

25

152



Tool Holder - Saw Blade

5

12.7

153



Tool Holder - Combo

5

6

153

CARBIDE DRILL BIT O SERIES

WITH UNIFORM DIAMETER

Long Flute Type

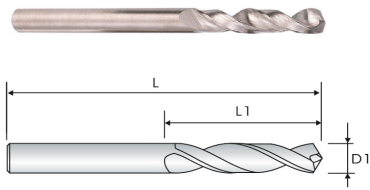

Part number	D1	L1	L	Part number	D1	L1	L
	Mill Dia.	Flute Length	Overall Length		Mill Dia.	Flute Length	Overall Length
ODX-0100-120Q11	1.0	12	34	ODX-0360-390Q11	3.6	39	70
ODX-0110-140Q11	1.1	14	36	ODX-0370-390Q11	3.7	39	70
ODX-0120-160Q11	1.2	16	38	ODX-0380-430Q11	3.8	43	75
ODX-0130-160Q11	1.3	16	38	ODX-0390-430Q11	3.9	43	75
ODX-0140-180Q11	1.4	18	40	ODX-0400-430Q11	4.0	43	75
ODX-0150-180Q11	1.5	18	40	ODX-0410-430Q11	4.1	43	75
ODX-0160-200Q11	1.6	20	43	ODX-0420-430Q11	4.2	43	75
ODX-0170-200Q11	1.7	20	43	ODX-0430-470Q11	4.3	47	80
ODX-0180-220Q11	1.8	22	46	ODX-0440-470Q11	4.4	47	80
ODX-0190-220Q11	1.9	22	46	ODX-0450-470Q11	4.5	47	80
ODX-0200-240Q11	2.0	24	49	ODX-0460-470Q11	4.6	47	80
ODX-0210-240Q11	2.1	24	49	ODX-0470-470Q11	4.7	47	80
ODX-0220-270Q11	2.2	27	53	ODX-0480-520Q11	4.8	52	86
ODX-0230-270Q11	2.3	27	53	ODX-0490-520Q11	4.9	52	86
ODX-0240-300Q11	2.4	30	57	ODX-0500-520Q11	5.0	52	86
ODX-0250-300Q11	2.5	30	57	ODX-0510-520Q11	5.1	52	86
ODX-0260-300Q11	2.6	30	57	ODX-0520-520Q11	5.2	52	86
ODX-0270-330Q11	2.7	33	61	ODX-0530-520Q11	5.3	52	86
ODX-0280-330Q11	2.8	33	61	ODX-0540-570Q11	5.4	57	93
ODX-0290-330Q11	2.9	33	61	ODX-0550-570Q11	5.5	57	93
ODX-0300-330Q11	3.0	33	61	ODX-0560-570Q11	5.6	57	93
ODX-0310-360Q11	3.1	36	65	ODX-0570-570Q11	5.7	57	93
ODX-0320-360Q11	3.2	36	65	ODX-0580-570Q11	5.8	57	93
ODX-0330-360Q11	3.3	36	65	ODX-0590-570Q11	5.9	57	93
ODX-0340-390Q11	3.4	39	70	ODX-0600-570Q11	6.0	57	93
ODX-0350-390Q11	3.5	39	70	ODX-0610-630Q11	6.1	63	101

Carbide Drill Bit

● Excellent ○ Good

Carbon Steels	Alloy Steels	Hardened Steels		High Hardened Steels	Copper	Cast iron	Aluminum	Stainless Steels	Titanium	Inconel
~HB225	HB225~325	HRc~50	HRc~55	HRc~60						
					●		●		○	

CARBIDE DRILL BIT

O SERIES

(CONTINUATION)

WITH UNIFORM DIAMETER

Long Flute Type

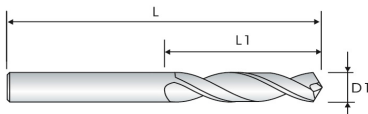

Part number	D1	L1	L	Part number	D1	L1	L
	Mill Dia.	Flute Length	Overall Length		Mill Dia.	Flute Length	Overall Length
ODX-0620-630Q11	6.2	63	101	ODX-0850-750Q11	8.5	75	117
ODX-0630-630Q11	6.3	63	101	ODX-0860-810Q11	8.6	81	125
ODX-0640-630Q11	6.4	63	101	ODX-0870-810Q11	8.7	81	125
ODX-0650-630Q11	6.5	63	101	ODX-0880-810Q11	8.8	81	125
ODX-0660-630Q11	6.6	63	101	ODX-0890-810Q11	8.9	81	125
ODX-0670-630Q11	6.7	63	101	ODX-0900-810Q11	9.0	81	125
ODX-0680-690Q11	6.8	69	109	ODX-0910-810Q11	9.1	81	125
ODX-0690-690Q11	6.9	69	109	ODX-0920-810Q11	9.2	81	125
ODX-0700-690Q11	7.0	69	109	ODX-0930-810Q11	9.3	81	125
ODX-0710-690Q11	7.1	69	109	ODX-0940-810Q11	9.4	81	125
ODX-0720-690Q11	7.2	69	109	ODX-0950-810Q11	9.5	81	125
ODX-0730-690Q11	7.3	69	109	ODX-0960-870Q11	9.6	87	133
ODX-0740-690Q11	7.4	69	109	ODX-0970-870Q11	9.7	87	133
ODX-0750-690Q11	7.5	69	109	ODX-0980-870Q11	9.8	87	133
ODX-0760-750Q11	7.6	75	117	ODX-0990-870Q11	9.9	87	133
ODX-0770-750Q11	7.7	75	117	ODX-1000-870Q11	10.0	87	133
ODX-0780-750Q11	7.8	75	117	ODX-1020-870Q11	10.2	87	133
ODX-0790-750Q11	7.9	75	117	ODX-1050-870Q11	10.5	87	133
ODX-0800-750Q11	8.0	75	117	ODX-1100-940Q11	11.0	94	142
ODX-0810-750Q11	8.1	75	117	ODX-1150-940Q11	11.5	94	142
ODX-0820-750Q11	8.2	75	117	ODX-1200-101Q11	12.0	101	151
ODX-0830-750Q11	8.3	75	117	ODX-1300-101Q11	13.0	101	151
ODX-0840-750Q11	8.4	75	117				

Carbide Drill Bit

● Excellent ○ Good

Carbon Steels	Alloy Steels	Hardened Steels		High Hardened Steels	Copper	Cast iron	Aluminum	Stainless Steels	Titanium	Inconel
~HB225	HB225~325	HRc~50	HRc~55	HRc~60						
					●		●		○	

CARBIDE DRILL BIT O SERIES

WITH UNIFORM DIAMETER

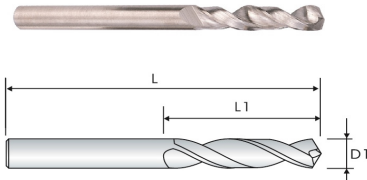

Part number	D1	L1	L	Part number	D1	L1	L
	Mill Dia.	Flute Length	Overall Length		Mill Dia.	Flute Length	Overall Length
ODX-0100-060Q11	1.0	6	26	ODX-0350-200Q11	3.5	20	52
ODX-0110-070Q11	1.1	7	28	ODX-0360-200Q11	3.6	20	52
ODX-0120-080Q11	1.2	8	30	ODX-0370-200Q11	3.7	20	52
ODX-0130-080Q11	1.3	8	30	ODX-0380-220Q11	3.8	22	55
ODX-0140-090Q11	1.4	9	32	ODX-0390-220Q11	3.9	22	55
ODX-0150-090Q11	1.5	9	32	ODX-0400-220Q11	4.0	22	55
ODX-0160-100Q11	1.6	10	34	ODX-0410-220Q11	4.1	22	55
ODX-0170-100Q11	1.7	10	34	ODX-0420-220Q11	4.2	22	55
ODX-0180-110Q11	1.8	11	36	ODX-0430-240Q11	4.3	24	58
ODX-0190-110Q11	1.9	11	36	ODX-0440-240Q11	4.4	24	58
ODX-0200-120Q11	2.0	12	38	ODX-0450-240Q11	4.5	24	58
ODX-0210-120Q11	2.1	12	38	ODX-0460-240Q11	4.6	24	58
ODX-0220-130Q11	2.2	13	40	ODX-0470-240Q11	4.7	24	58
ODX-0230-130Q11	2.3	13	40	ODX-0480-260Q11	4.8	26	62
ODX-0240-140Q11	2.4	14	43	ODX-0490-260Q11	4.9	26	62
ODX-0250-140Q11	2.5	14	43	ODX-0500-260Q11	5.0	26	62
ODX-0260-140Q11	2.6	14	43	ODX-0510-260Q11	5.1	26	62
ODX-0270-140Q11	2.7	14	46	ODX-0520-260Q11	5.2	26	65
ODX-0280-160Q11	2.8	16	46	ODX-0530-260Q11	5.3	26	65
ODX-0290-160Q11	2.9	16	46	ODX-0540-280Q11	5.4	28	66
ODX-0300-160Q11	3.0	16	46	ODX-0550-280Q11	5.5	28	66
ODX-0310-180Q11	3.1	18	49	ODX-0560-280Q11	5.6	28	66
ODX-0320-180Q11	3.2	18	49	ODX-0570-280Q11	5.7	28	66
ODX-0330-180Q11	3.3	18	49	ODX-0580-280Q11	5.8	28	66
ODX-0340-200Q11	3.4	20	52	ODX-0590-280Q11	5.9	28	66

Carbide Drill Bit

● Excellent ○ Good

Carbon Steels	Alloy Steels	Hardened Steels		High Hardened Steels	Copper	Cast iron	Aluminum	Stainless Steels	Titanium	Inconel
~HB225	HB225~325	HRc~50	HRc~55	HRc~60						
					●		●			

CARBIDE DRILL BIT

O SERIES

(CONTINUATION)

WITH UNIFORM DIAMETER

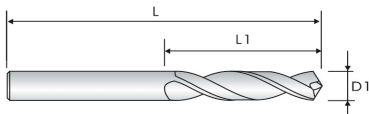

Part number	D1	L1	L
	Mill Dia.	Flute Length	Overall Length
ODX-0600-280Q11	6.0	28	66
ODX-0610-310Q11	6.1	31	70
ODX-0620-310Q11	6.2	31	70
ODX-0630-310Q11	6.3	31	70
ODX-0640-310Q11	6.4	31	70
ODX-0650-310Q11	6.5	31	70
ODX-0660-310Q11	6.6	31	70
ODX-0670-310Q11	6.7	31	70
ODX-0680-340Q11	6.8	34	74
ODX-0690-340Q11	6.9	34	74
ODX-0700-340Q11	7.0	34	74
ODX-0710-340Q11	7.1	34	74
ODX-0720-340Q11	7.2	34	74
ODX-0730-340Q11	7.3	34	74
ODX-0740-340Q11	7.4	34	74
ODX-0750-340Q11	7.5	34	74
ODX-0760-370Q11	7.6	37	79
ODX-0770-370Q11	7.7	37	79

Carbide Drill Bit

● Excellent ○ Good

Carbon Steels	Alloy Steels	Hardened Steels		High Hardened Steels	Copper	Cast iron	Aluminum	Stainless Steels	Titanium	Inconel
~HB225	HB225~325	HRC~50	HRC~55	HRC~60						
					●		●			

CARBIDE DRILL BIT O SERIES

WITH UNIFORM DIAMETER

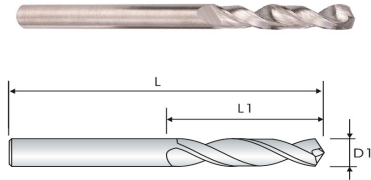

Part number	D1	L1	L	Part number	D1	L1	L
	Mill Dia.	Flute Length	Overall Length		Mill Dia.	Flute Length	Overall Length
ODX-0780-370Q11	7.8	37	79	ODX-1030-430Q11	10.3	43	89
ODX-0790-370Q11	7.9	37	79	ODX-1040-430Q11	10.4	43	89
ODX-0800-370Q11	8.0	37	79	ODX-1050-430Q21	10.5	43	89
ODX-0810-370Q11	8.1	37	79	ODX-1060-430Q11	10.6	43	89
ODX-0820-370Q11	8.2	37	79	ODX-1070-430Q11	10.7	43	89
ODX-0830-370Q11	8.3	37	79	ODX-1080-430Q11	10.8	43	89
ODX-0840-370Q11	8.4	37	79	ODX-1090-430Q11	10.9	43	89
ODX-0850-370Q11	8.5	37	79	ODX-1100-430Q11	11.0	43	89
ODX-0860-400Q11	8.6	40	84	ODX-1110-470Q11	11.1	47	95
ODX-0870-400Q11	8.7	40	84	ODX-1120-470Q11	11.2	47	95
ODX-0880-400Q11	8.8	40	84	ODX-1130-470Q11	11.3	47	95
ODX-0890-400Q11	8.9	40	84	ODX-1140-470Q11	11.4	47	95
ODX-0900-400Q11	9.0	40	84	ODX-1150-470Q11	11.5	47	95
ODX-0910-400Q11	9.1	40	84	ODX-1160-470Q11	11.6	47	95
ODX-0920-400Q11	9.2	40	84	ODX-1170-470Q11	11.7	47	95
ODX-0930-400Q11	9.3	40	84	ODX-1180-470Q11	11.8	47	95
ODX-0940-400Q11	9.4	40	84	ODX-1190-470Q11	11.9	47	95
ODX-0950-400Q11	9.5	40	84	ODX-1200-470Q11	12.0	47	95
ODX-0960-430Q11	9.6	43	89	ODX-1210-510Q11	12.1	51	102
ODX-0970-430Q11	9.7	43	89	ODX-1220-510Q11	12.2	51	102
ODX-0980-430Q11	9.8	43	89	ODX-1230-510Q11	12.3	51	102
ODX-0990-430Q11	9.9	43	89	ODX-1240-510Q11	12.4	51	102
ODX-1000-430Q11	10.0	43	89	ODX-1250-510Q11	12.5	51	102
ODX-1010-430Q11	10.1	43	89	ODX-1260-510Q11	12.6	51	102
ODX-1020-430Q11	10.2	43	89	ODX-1270-510Q11	12.7	51	102
ODX-1020-430Q11	10.2	43	89	ODX-1280-510Q11	12.8	51	102

Carbide Drill Bit

● Excellent ○ Good

Carbon Steels	Alloy Steels	Hardened Steels		High Hardened Steels	Copper	Cast iron	Aluminum	Stainless Steels	Titanium	Inconel
~HB225	HB225~325	HRc~50	HRc~55	HRc~60						
					●		●			

CARBIDE DRILL BIT

O SERIES

(CONTINUATION)

WITH UNIFORM DIAMETER

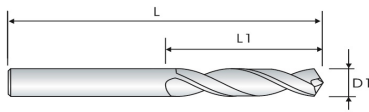

Part number	D1	L1	L
	Mill Dia.	Flute Length	Overall Length
ODX-1290-510Q11	12.9	51	102
ODX-1300-510Q11	13.0	51	102
ODX-1310-510Q11	13.1	51	102
ODX-1320-510Q11	13.2	51	102
ODX-1330-510Q11	13.3	51	102
ODX-1340-510Q11	13.4	51	102
ODX-1350-510Q11	13.5	51	102
ODX-1360-510Q11	13.6	51	102
ODX-1370-510Q11	13.7	51	102
ODX-1380-510Q11	13.8	51	102
ODX-1390-510Q11	13.9	51	102
ODX-1400-510Q11	14.0	51	102

Carbide Drill Bit

● Excellent ○ Good

Carbon Steels	Alloy Steels	Hardened Steels		High Hardened Steels	Copper	Cast iron	Aluminum	Stainless Steels	Titanium	Inconel
		~HB225	HB225~325	HRc~50						
					●		●			

CARBIDE DRILL BIT O SERIES

WITH STEPPED SHANK

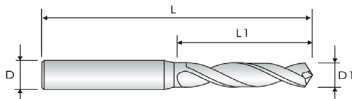

Part number	D1	L1	L	d
	Mill Dia.	Flute Length	Overall Length	Shank Dia.
ODX-0100-060B11	1.0	6	38	3
ODX-0110-070B11	1.1	7	38	3
ODX-0120-080B11	1.2	8	38	3
ODX-0130-080B11	1.3	8	38	3
ODX-0140-090B11	1.4	9	38	3
ODX-0150-090B11	1.5	9	38	3
ODX-0160-100B11	1.6	10	38	3
ODX-0170-100B11	1.7	10	38	3
ODX-0180-110B11	1.8	11	38	3
ODX-0190-110B11	1.9	11	38	3
ODX-0200-120B11	2.0	12	38	3
ODX-0210-120B11	2.1	12	50	3
ODX-0220-130B11	2.2	13	50	3
ODX-0230-130B11	2.3	13	50	3
ODX-0240-140B11	2.4	14	50	3
ODX-0250-140B11	2.5	14	50	3
ODX-0260-140B11	2.6	14	50	3
ODX-0270-140B11	2.7	14	50	3
ODX-0280-160B11	2.8	16	50	3
ODX-0290-160B11	2.9	16	50	3
ODX-0300-160B11	3.0	16	50	3
ODX-0310-180C11	3.1	18	60	4
ODX-0320-180C11	3.2	18	60	4
ODX-0330-180C11	3.3	18	60	4
ODX-0340-200C11	3.4	20	60	4
ODX-0350-200C11	3.5	20	60	4

Carbide Drill Bit

● Excellent ○ Good

Carbon Steels	Alloy Steels	Hardened Steels		High Hardened Steels	Copper	Cast iron	Aluminum	Stainless Steels	Titanium	Inconel
~HB225	HB225~325	HRc~50	HRc~55	HRc~60						
					●		●			

CARBIDE DRILL BIT

O SERIES

(CONTINUATION)

WITH STEPPED SHANK

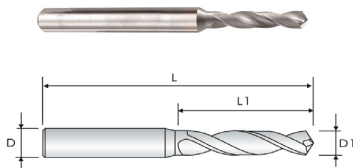

Part number	D1	L1	L	d
	Mill Dia.	Flute Length	Overall Length	Shank Dia.
ODX-0360-200C11	3.6	20	60	4
ODX-0370-200C11	3.7	20	60	4
ODX-0380-220C11	3.8	22	60	4
ODX-0390-220C11	3.9	22	60	4
ODX-0400-220C11	4.0	22	60	4
ODX-0410-220E11	4.1	22	60	6
ODX-0420-220E11	4.2	22	60	6
ODX-0430-240E11	4.3	24	60	6
ODX-0440-240E11	4.4	24	60	6
ODX-0450-240E11	4.5	24	60	6
ODX-0460-240E11	4.6	24	60	6
ODX-0470-240E11	4.7	24	60	6
ODX-0480-260E11	4.8	26	60	6
ODX-0490-260E11	4.9	26	60	6
ODX-0500-260E11	5.0	26	60	6
ODX-0510-260E11	5.1	26	60	6
ODX-0520-260E11	5.2	26	60	6
ODX-0530-260E11	5.3	26	60	6
ODX-0540-280E11	5.4	28	60	6
ODX-0550-280E11	5.5	28	60	6
ODX-0560-280E11	5.6	28	60	6
ODX-0570-280E11	5.7	28	60	6
ODX-0580-280E11	5.8	28	60	6
ODX-0590-280E11	5.9	28	60	6
ODX-0600-280E11	6.0	28	60	6

Carbide Drill Bit

● Excellent ○ Good

Carbon Steels	Alloy Steels	Hardened Steels		High Hardened Steels	Copper	Cast iron	Aluminum	Stainless Steels	Titanium	Inconel
~HB225	HB225~325	HRC~50	HRC~55	HRC~60						
					●		●			

CARBIDE DRILL BIT O SERIES

WITH EXTENDED NECK

Long Flute Type

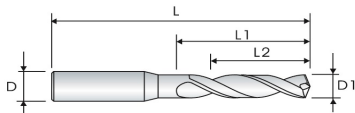

Part number	D1	L2	L1	L	d
	Mill Dia.	Max. Drill Depth	Flute Length	Overall Length	Shank Dia.
ODL-0150-100C11	1.5	6	10	47	4
ODL-0160-100C11	1.6	6	10	47	4
ODL-0170-100C11	1.7	6	10	47	4
ODL-0180-120C11	1.8	8	12	47	4
ODL-0190-120C11	1.9	8	12	47	4
ODL-0200-150C11	2.0	11	15	55	4
ODL-0210-150C11	2.1	11	15	55	4
ODL-0220-150C11	2.2	11	15	55	4
ODL-0230-150C11	2.3	11	15	55	4
ODL-0240-150C11	2.4	11	15	55	4
ODL-0250-150C11	2.5	11	15	55	4
ODL-0260-180C11	2.6	13	18	55	4
ODL-0270-180C11	2.7	13	18	55	4
ODL-0280-180C11	2.8	13	18	55	4
ODL-0290-180C11	2.9	13	18	55	4
ODL-0300-200C11	3.0	14	20	62	4
ODL-0310-200C11	3.1	14	20	62	4
ODL-0320-200C11	3.2	14	20	62	4
ODL-0330-200C11	3.3	14	20	62	4
ODL-0340-200C11	3.4	14	20	62	4
ODL-0350-200C11	3.5	14	20	62	4
ODL-0360-200E11	3.6	14	20	62	6
ODL-0370-200E11	3.7	14	20	62	6
ODL-0380-200E11	3.8	14	20	62	6
ODL-0390-200E11	3.9	14	20	62	6

Carbide Drill Bit

● Excellent ○ Good

Carbon Steels	Alloy Steels	Hardened Steels		High Hardened Steels	Copper	Cast iron	Aluminum	Stainless Steels	Titanium	Inconel
~HB225	HB225~325	HRc~50	HRc~55	HRc~60						
●	●					●		●	●	

CARBIDE DRILL BIT

O SERIES

(CONTINUATION)

WITH EXTENDED NECK

Long Flute Type

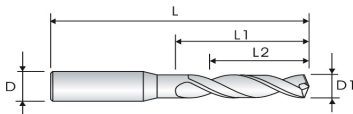

Part number	D1	L2	L1	L	d
	Mill Dia.	Max. Drill Depth	Flute Length	Overall Length	Shank Dia.
ODL-0400-240E11	4.0	17	24	66	6
ODL-0410-240E11	4.1	17	24	66	6
ODL-0420-240E11	4.2	17	24	66	6
ODL-0430-240E11	4.3	17	24	66	6
ODL-0440-240E11	4.4	17	24	66	6
ODL-0450-240E11	4.5	17	24	66	6
ODL-0460-240E11	4.6	17	24	66	6
ODL-0470-280E11	4.7	20	28	66	6
ODL-0480-280E11	4.8	20	28	66	6
ODL-0490-280E11	4.9	20	28	66	6
ODL-0500-280E11	5.0	20	28	66	6
ODL-0510-280E11	5.1	20	28	66	6
ODL-0520-280E11	5.2	20	28	66	6
ODL-0530-280E11	5.3	20	28	66	6
ODL-0540-280E11	5.4	20	28	66	6
ODL-0550-280G11	5.5	20	28	66	8
ODL-0560-280G11	5.6	20	28	66	8
ODL-0570-280G11	5.7	20	28	66	8
ODL-0580-280G11	5.8	20	28	66	8
ODL-0590-280G11	5.9	20	28	66	8
ODL-0600-280G11	6.0	20	28	66	8
ODL-0610-340G11	6.1	24	34	79	8
ODL-0620-340G11	6.2	24	34	79	8
ODL-0630-340G11	6.3	24	34	79	8
ODL-0640-340G11	6.4	24	34	79	8

Carbide Drill Bit

● Excellent ○ Good

Carbon Steels	Alloy Steels	Hardened Steels		High Hardened Steels	Copper	Cast iron	Aluminum	Stainless Steels	Titanium	Inconel
~HB225	HB225~325	HRC~50	HRC~55	HRC~60						
●	●					●		●	●	

CARBIDE DRILL BIT O SERIES

(CONTINUATION)

WITH EXTENDED NECK

Long Flute Type

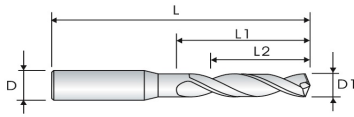

Part number	D1	L2	L1	L	d
	Mill Dia.	Max. Drill Depth	Flute Length	Overall Length	Shank Dia.
ODL-0650-340G11	6.5	24	34	79	8
ODL-0660-340G11	6.6	24	34	79	8
ODL-0670-340G11	6.7	24	34	79	8
ODL-0680-340G11	6.8	24	34	79	8
ODL-0690-340G11	6.9	24	34	79	8
ODL-0700-340G11	7.0	24	34	79	8
ODL-0710-410G11	7.1	29	41	79	8
ODL-0720-410G11	7.2	29	41	79	8
ODL-0730-410G11	7.3	29	41	79	8
ODL-0740-410G11	7.4	29	41	79	8
ODL-0750-410G11	7.5	29	41	79	8
ODL-0760-410G11	7.6	29	41	79	8
ODL-0770-410G11	7.7	29	41	79	8
ODL-0780-410G11	7.8	29	41	79	8
ODL-0790-410G11	7.9	29	41	79	8
ODL-0800-410G11	8.0	29	41	79	8
ODL-0810-470H11	8.1	35	47	89	10
ODL-0820-470H11	8.2	35	47	89	10

Carbide Drill Bit

● Excellent ○ Good

Carbon Steels	Alloy Steels	Hardened Steels		High Hardened Steels	Copper	Cast iron	Aluminum	Stainless Steels	Titanium	Inconel
~HB225	HB225~325	HRC~50	HRC~55	HRC~60						
●	●					●		●	●	

CARBIDE DRILL BIT

O SERIES

WITH EXTENDED NECK

Long Flute Type

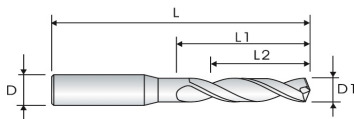

Part number	D1	L2	L1	L	d
	Mill Dia.	Max. Drill Depth	Flute Length	Overall Length	Shank Dia.
ODX-0830-470H11	8.3	35	47	89	10
ODX-0840-470H11	8.4	35	47	89	10
ODX-0850-470H11	8.5	35	47	89	10
ODX-0860-470H11	8.6	35	47	89	10
ODX-0870-470H11	8.7	35	47	89	10
ODX-0880-470H11	8.8	35	47	89	10
ODX-0890-470H11	8.9	35	47	89	10
ODX-0900-470H11	9.0	35	47	89	10
ODX-0910-470H11	9.1	35	47	89	10
ODX-0920-470H11	9.2	35	47	89	10
ODX-0930-470H11	9.3	35	47	89	10
ODX-0940-470H11	9.4	35	47	89	10
ODX-0950-470H11	9.5	35	47	89	10
ODX-0960-470H11	9.6	35	47	89	10
ODX-0970-470H11	9.7	35	47	89	10
ODX-0980-470H11	9.8	35	47	89	10
ODX-0990-470H11	9.9	35	47	89	10
ODX-1000-470H11	10.0	35	47	89	10
ODX-1010-550I11	10.1	40	55	102	12
ODX-1020-550I11	10.2	40	55	102	12
JCTE1252101	10.2	40	55	102	12
JCTE1252201	10.2	40	55	102	12
JCTE1252301	10.2	40	55	102	12
JCTE1252401	10.2	40	55	102	12
JCTE1252501	10.2	40	55	102	12

Carbide Drill Bit

● Excellent ○ Good

Carbon Steels	Alloy Steels	Hardened Steels		High Hardened Steels	Copper	Cast iron	Aluminum	Stainless Steels	Titanium	Inconel
~HB225	HB225~325	HRC~50	HRC~55	HRC~60						
●	●					●		●	●	

CARBIDE DRILL BIT O SERIES

(CONTINUATION)

WITH EXTENDED NECK

Long Flute Type

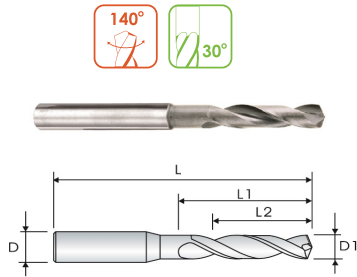

Part number	D1	L2	L1	L	d
	Mill Dia.	Max. Drill Depth	Flute Length	Overall Length	Shank Dia.
ODX-1030-550I11	10.3	40	55	102	12
ODX-1040-550I11	10.4	40	55	102	12
ODX-1050-550I11	10.5	40	55	102	12
ODX-1060-550I11	10.6	40	55	102	12
ODX-1070-550I11	10.7	40	55	102	12
ODX-1080-550I11	10.8	40	55	102	12
ODX-1090-550I11	10.9	40	55	102	12
ODX-1100-550I11	11.0	40	55	102	12
ODX-1110-550I11	11.1	40	55	102	12
ODX-1120-550I11	11.2	40	55	102	12
ODX-1130-550I11	11.3	40	55	102	12
ODX-1140-550I11	11.4	40	55	102	12
ODX-1150-550I11	11.5	40	55	102	12
ODX-1160-550I11	11.6	40	55	102	12
ODX-1170-550I11	11.7	40	55	102	12
ODX-1180-550I11	11.8	40	55	102	12
ODX-1190-550I11	11.9	40	55	102	12
ODX-1200-550I11	12.0	40	55	102	12

Carbide Drill Bit

● Excellent ○ Good

Carbon Steels	Alloy Steels	Hardened Steels		High Hardened Steels	Copper	Cast iron	Aluminum	Stainless Steels	Titanium	Inconel
~HB225	HB225~325	HRc~50	HRc~55	HRc~60						
●	●					●		●	●	

CARBIDE DRILL BIT

O SERIES

WITH UNIFORM DIAMETER

Left Hand

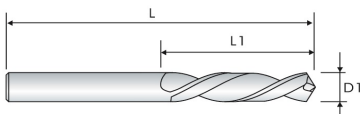

Part number	D1	L1	L	Part number	D1	L1	L
	Mill Dia.	Flute Length	Overall Length		Mill Dia.	Flute Length	Overall Length
ODX-0100-080Q11	1.00	8	40	ODX-0184-140Q11	1.84	14	40
ODX-0110-100Q11	1.10	10	40	ODX-0185-140Q11	1.85	14	40
ODX-0120-100Q11	1.20	10	40	ODX-0190-140Q11	1.90	14	40
ODX-0124-120Q11	1.24	12	40	ODX-0195-140Q11	1.95	14	40
ODX-0125-120Q11	1.25	12	40	ODX-0196-120Q11	1.96	12	40
ODX-0126-120Q11	1.26	12	40	ODX-0197-120Q11	1.97	12	40
ODX-0130-120Q11	1.30	12	40	ODX-0198-120Q11	1.98	12	40
ODX-0140-120Q11	1.40	12	40	ODX-0200-160Q11	2.00	16	40
ODX-0141-120Q11	1.41	12	40	ODX-0210-160Q11	2.10	16	40
ODX-0142-120Q11	1.42	12	40	ODX-0220-160Q11	2.20	16	40
ODX-0143-120Q11	1.43	12	40	ODX-0225-160Q11	2.25	16	40
ODX-0144-120Q11	1.44	12	40	ODX-0226-160Q11	2.26	16	40
ODX-0145-120Q11	1.45	12	40	ODX-0227-160Q11	2.27	16	40
ODX-0146-120Q11	1.46	12	40	ODX-0228-160Q11	2.28	16	40
ODX-0150-120Q11	1.50	12	40	ODX-0229-160Q11	2.29	16	40
ODX-0155-120Q11	1.55	12	40	ODX-0230-160Q11	2.30	16	40
ODX-0160-120Q11	1.60	12	40	ODX-0231-160Q11	2.31	16	40
ODX-0165-120Q11	1.65	12	40	ODX-0232-160Q11	2.32	16	40
ODX-0170-120Q11	1.70	12	40	ODX-0233-160Q11	2.33	16	40
ODX-0178-120Q11	1.78	12	40	ODX-0240-160Q11	2.40	16	40
ODX-0179-120Q11	1.79	12	40	ODX-0250-160Q11	2.50	16	40
ODX-0180-140Q11	1.80	14	40	ODX-0255-160Q11	2.55	16	40
ODX-0181-140Q11	1.81	14	40	ODX-0256-160Q11	2.56	16	40
ODX-0182-140Q11	1.82	14	40	ODX-0257-160Q11	2.57	16	40
ODX-0183-140Q11	1.83	14	40	ODX-0258-210Q11	2.58	21	50

Carbide Drill Bit

● Excellent ○ Good

Carbon Steels	Alloy Steels	Hardened Steels		High Hardened Steels	Copper	Cast iron	Aluminum	Stainless Steels	Titanium	Inconel
~HB225	HB225~325	HRC~50	HRC~55	HRC~60						
					●		●			

CARBIDE DRILL BIT

O SERIES

(CONTINUATION)

WITH UNIFORM DIAMETER

Left Hand

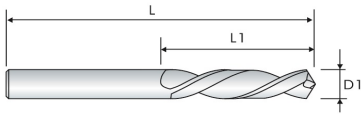

Part number	D1	L1	L
	Mill Dia.	Flute Length	Overall Length
ODX-0260-210Q11	2.60	21	50
ODX-0270-210Q11	2.70	21	50
ODX-0274-210Q11	2.74	21	50
ODX-0275-210Q11	2.75	21	50
ODX-0276-210Q11	2.76	21	50
ODX-0277-210Q11	2.77	21	50
ODX-0278-210Q11	2.78	21	50
ODX-0279-210Q11	2.79	21	50
ODX-0280-210Q21	2.80	21	50
ODX-0281-210Q11	2.81	21	50
ODX-0282-210Q11	2.82	21	50
ODX-0290-210Q11	2.90	21	50
ODX-0300-210Q11	3.00	21	50
ODX-0310-210Q11	3.10	21	50
ODX-0315-210Q11	3.15	21	50
ODX-0316-210Q11	3.16	21	50
ODX-0317-210Q11	3.17	21	50
ODX-0318-210Q11	3.18	21	50

Carbide Drill Bit

● Excellent ○ Good

Carbon Steels	Alloy Steels	Hardened Steels		High Hardened Steels	Copper	Cast iron	Aluminum	Stainless Steels	Titanium	Inconel
~HB225	HB225~325	HRc~50	HRc~55	HRc~60						
					●		●			

CARBIDE DRILL BIT

O SERIES

WITH UNIFORM DIAMETER

Left Hand

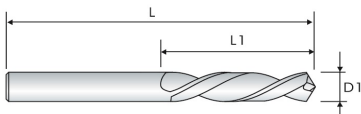

Part number	D1	L1	L	Part number	D1	L1	L
	Mill Dia.	Flute Length	Overall Length		Mill Dia.	Flute Length	Overall Length
ODX-0320-210Q11	3.20	21	50	ODX-0460-250Q11	4.60	25	50
ODX-0322-210Q11	3.22	21	50	ODX-0465-250Q11	4.65	25	50
ODX-0323-210Q11	3.23	21	50	ODX-0466-250Q11	4.66	25	50
ODX-0324-210Q11	3.24	21	50	ODX-0467-250Q11	4.67	25	50
ODX-0325-210Q11	3.25	21	50	ODX-0468-250Q11	4.68	25	50
ODX-0326-210Q11	3.26	21	50	ODX-0470-250Q11	4.70	25	50
ODX-0327-210Q11	3.27	21	50	ODX-0480-250Q11	4.80	25	50
ODX-0328-210Q11	3.28	21	50	ODX-0490-250Q11	4.90	25	50
ODX-0340-210Q11	3.40	21	50	ODX-0500-250Q11	5.00	25	50
ODX-0345-210Q11	3.45	21	50	ODX-0510-250Q11	5.10	25	50
ODX-0350-210Q11	3.50	21	50	ODX-0520-250Q11	5.20	25	50
ODX-0360-210Q11	3.60	21	50	ODX-0530-250Q11	5.30	25	50
ODX-0365-210Q11	3.65	21	50	ODX-0540-250Q11	5.40	25	50
ODX-0366-210Q11	3.66	21	50	ODX-0550-250Q11	5.50	25	50
ODX-0367-210Q11	3.67	21	50	ODX-0555-250Q11	5.55	25	50
ODX-0368-210Q11	3.68	21	50	ODX-0556-250Q11	5.56	25	50
ODX-0370-210Q11	3.70	21	50	ODX-0557-250Q11	5.57	25	50
ODX-0380-250Q11	3.80	25	50	ODX-0558-250Q11	5.58	25	50
ODX-0381-250Q11	3.81	25	50	ODX-0560-250Q11	5.60	25	50
ODX-0390-250Q11	3.90	25	50	ODX-0570-250Q11	5.70	25	50
ODX-0400-250Q11	4.00	25	50	ODX-0580-250Q11	5.80	25	50
ODX-0410-250Q11	4.10	25	50	ODX-0590-250Q11	5.90	25	50
ODX-0420-250Q11	4.20	25	50	ODX-0600-250Q11	6.00	25	50
ODX-0430-250Q11	4.30	25	50	ODX-0610-250Q11	6.10	25	50
ODX-0440-250Q11	4.40	25	50	ODX-0620-250Q11	6.20	25	50
ODX-0444-250Q11	4.44	25	50	ODX-0630-250Q11	6.30	25	50
ODX-0445-250Q11	4.45	25	50	ODX-0640-250Q11	6.40	25	50
ODX-0446-250Q11	4.46	25	50	ODX-0650-250Q11	6.50	25	50
ODX-0450-250Q11	4.50	25	50				

Carbide Drill Bit

● Excellent ○ Good

Carbon Steels	Alloy Steels	Hardened Steels		High Hardened Steels	Copper	Cast iron	Aluminum	Stainless Steels	Titanium	Inconel
~HB225	HB225~325	HRC~50	HRC~55	HRC~60						
					●		●			

CARBIDE DRILL BIT O SERIES

MINIATURE

1/8" Shank

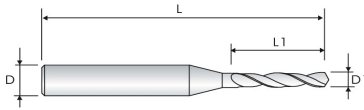

Part number	D1	L1	L	d
	Mill Dia.	Flute Length	Overall Length	Shank Dia.
ODX-0020-030P11	0.20	3.0	38	3.175
ODX-0025-040P11	0.25	4.0	38	3.175
ODX-0030-050P11	0.30	5.0	38	3.175
ODX-0035-050P11	0.35	5.0	38	3.175
ODX-0040-055P11	0.40	5.5	38	3.175
ODX-0045-050P11	0.45	5.0	38	3.175
ODX-0050-070P11	0.50	7.0	38	3.175
ODX-0055-070P11	0.55	7.0	38	3.175
ODX-0060-070P11	0.60	7.0	38	3.175
ODX-0065-080P11	0.65	8.0	38	3.175
ODX-0070-080P11	0.70	8.0	38	3.175
ODX-0075-080P11	0.75	8.0	38	3.175
ODX-0080-080P11	0.80	8.0	38	3.175
ODX-0085-080P11	0.85	8.0	38	3.175
ODX-0090-100P11	0.90	10.0	38	3.175
ODX-0095-100P11	0.95	10.0	38	3.175
ODX-0100-100P11	1.00	10.0	38	3.175
ODX-0105-120P11	1.05	12.0	38	3.175
ODX-0110-120P11	1.10	12.0	38	3.175
ODX-0115-120P11	1.15	12.0	38	3.175
ODX-0120-120P11	1.20	12.0	38	3.175
ODX-0125-120P11	1.25	12.0	38	3.175
ODX-0130-120P11	1.30	12.0	38	3.175
ODX-0135-120P11	1.35	12.0	38	3.175
ODX-0140-120P11	1.40	12.0	38	3.175
ODX-0145-120P11	1.45	12.0	38	3.175
ODX-0150-120P11	1.50	12.0	38	3.175
ODX-0155-120P11	1.55	12.0	38	3.175
ODX-0160-120P11	1.60	12.0	38	3.175

Carbide Drill Bit

● Excellent ○ Good

Carbon Steels	Alloy Steels	Hardened Steels		High Hardened Steels	Copper	Cast iron	Aluminum	Stainless Steels	Titanium	Inconel
~HB225	HB225~325	HRC~50	HRC~55	HRC~60						
					●		●			

CARBIDE DRILL BIT

O SERIES

(CONTINUATION)

MINIATURE

1/8" Shank

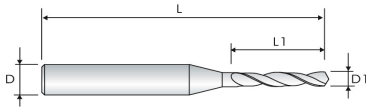

Part number	D1	L1	L	d
	Mill Dia.	Flute Length	Overall Length	Shank Dia.
ODX-0165-120P11	1.65	12	38	3.175
ODX-0170-120P11	1.70	12	38	3.175
ODX-0175-120P11	1.75	12	38	3.175
ODX-0180-120P11	1.80	12	38	3.175
ODX-0185-120P11	1.85	12	38	3.175
ODX-0190-120P11	1.90	12	38	3.175
ODX-0195-120P11	1.95	12	38	3.175
ODX-0200-120P11	2.00	12	38	3.175
ODX-0205-120P11	2.05	12	38	3.175
ODX-0210-120P11	2.10	12	38	3.175
ODX-0215-120P11	2.15	12	38	3.175
ODX-0220-120P11	2.20	12	38	3.175
ODX-0225-120P11	2.25	12	38	3.175
ODX-0230-120P11	2.30	12	38	3.175
ODX-0235-120P11	2.35	12	38	3.175
ODX-0240-120P11	2.40	12	38	3.175
ODX-0245-120P11	2.45	12	38	3.175
ODX-0250-120P11	2.50	12	38	3.175
ODX-0255-120P11	2.55	12	38	3.175
ODX-0260-120P11	2.60	12	38	3.175
ODX-0265-120P11	2.65	12	38	3.175
ODX-0270-120P11	2.70	12	38	3.175
ODX-0275-120P11	2.75	12	38	3.175
ODX-0280-120P11	2.80	12	38	3.175
ODX-0285-120P11	2.85	12	38	3.175
ODX-0290-120P11	2.90	12	38	3.175
ODX-0295-120P11	2.95	12	38	3.175
ODX-0305-120P11	3.05	12	38	3.175
ODX-0315-120P11	3.15	12	38	3.175
ODX-0317-120P11	3.175	12	38	3.175

Carbide Drill Bit

● Excellent ○ Good

Carbon Steels	Alloy Steels	Hardened Steels		High Hardened Steels	Copper	Cast iron	Aluminum	Stainless Steels	Titanium	Inconel
~HB225	HB225~325	HRC~50	HRC~55	HRC~60						
					●		●			

CARBIDE POSITION DRILL O SERIES



HELIX

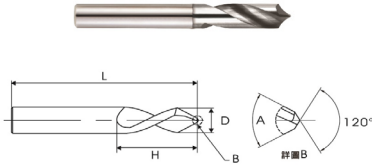

Part number	D1	Point Angle	L1	L
	Mill Dia.		Flute Length	Overall Length
ODC-0200-060R11	2	60°	6	38
ODC-0300-100R11	3	60°	10	38
ODC-0400-120R11	4	60°	12	50
ODC-0500-150R11	5	60°	15	50
ODC-0600-200R11	6	60°	20	50
ODC-0700-200R11	7	60°	20	50
ODC-0800-200R11	8	60°	20	60
ODC-1000-220R11	10	60°	22	75
ODC-1200-250R11	12	60°	25	75
ODC-0200-060R21	2	90°	6	38
ODC-0300-100R21	3	90°	10	38
ODC-0400-120R21	4	90°	12	50
ODC-0500-150R21	5	90°	15	50
ODC-0600-200R21	6	90°	20	50
ODC-0700-200R21	7	90°	20	50
ODC-0800-200R21	8	90°	20	60
ODC-1000-220R21	10	90°	22	75
ODC-1200-250R21	12	90°	25	75
ODC-1600-240Q11	16	90°	34	75
ODC-0300-100R31	3	120°	10	38
ODC-0400-120R31	4	120°	12	50
ODC-0500-150R31	5	120°	15	50
ODC-0600-200R31	6	120°	20	50
ODC-0700-200R31	7	120°	20	50
ODC-0800-200R31	8	120°	20	60
ODC-1000-220R31	10	120°	22	75
ODC-1200-250R31	12	120°	25	75

Carbide Drill Bit

● Excellent ○ Good

Carbon Steels	Alloy Steels	Hardened Steels		High Hardened Steels	Copper	Cast iron	Aluminum	Stainless Steels	Titanium	Inconel
~HB225	HB225~325	HRc~50	HRc~55	HRc~60						
					●		●			

CARBIDE POSITION DRILL

O SERIES

FLAT TIP

Right Hand - Double Heads



Part number	D1	Point Angle	L	d
	Mill Dia.		Flute Length	Overall Length
ODX-0300-060B11	3.00	60°	50	3
ODX-0300-090B11	3.00	90°	50	3
ODX-0400-060C11	4.00	60°	50	4
ODX-0400-090C11	4.00	90°	50	4
ODX-0500-060D11	5.00	60°	50	5
ODX-0500-090D11	5.00	90°	50	5
ODX-0600-060E11	6.00	60°	50	6
ODX-0600-090E11	6.00	90°	50	6

PYRAMID - TIP



Part number	D1	Point Angle	L1
	Mill Dia.		Overall Length
ODC-0400-060Q11	4	60°	40
ODC-0400-090Q11	4	90°	40
ODC-0400-120Q11	4	120°	40

Carbide Drill Bit

● Excellent ○ Good

Carbon Steels	Alloy Steels	Hardened Steels		High Hardened Steels	Copper	Cast iron	Aluminum	Stainless Steels	Titanium	Inconel
~HB225	HB225~325	HRC~50	HRC~55	HRC~60						
					●		●			

CARBIDE CENTER DRILL O SERIES

DOUBLE HEADS

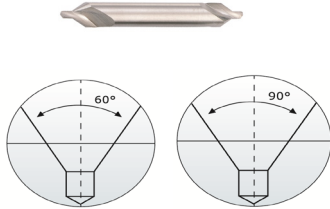

Part number	D1	CA	L1	L	d
	Mill Dia.	Taper Angle	Flute Length	Overall Length	Shank Dia.
ODX-0100-060C11	1	60°	2	40	4
ODX-0100-090C11	1	90°	2	40	4
ODX-0150-060C11	1.5	60°	2	40	4
ODX-0150-090C11	1.5	90°	2	40	4
ODX-0150-060E11	1.5	60°	2	50	6
ODX-0150-090E11	1.5	90°	2	50	6
ODX-0200-060C11	2	60°	3	40	4
ODX-0200-090C11	2	90°	3	40	4
ODX-0200-060E11	2	60°	3	50	6
ODX-0200-090E11	2	90°	3	50	6
ODX-0250-060E11	2.5	60°	3	50	6
ODX-0250-090E11	2.5	90°	3	50	6
ODX-0300-060E11	3	60°	4	50	6
ODX-0300-090E11	3	90°	4	50	6
ODX-0300-060G11	3	60°	4	60	8
ODX-0300-090G11	3	90°	4	60	8
ODX-0400-060E11	4	60°	5	50	6
ODX-0400-090E11	4	90°	5	50	6
ODX-0400-060H11	4	60°	5	75	10
ODX-0400-090H11	4	90°	5	75	10
ODX-0500-060I11	5	60°	6.3	75	12
ODX-0500-090I11	5	90°	6.3	75	12

Carbide Drill Bit

● Excellent ○ Good

Carbon Steels	Alloy Steels	Hardened Steels		High Hardened Steels	Copper	Cast iron	Aluminum	Stainless Steels	Titanium	Inconel
~HB225	HB225~325	HRc~50	HRc~55	HRc~60						
	●				●	●	●		○	

CARBIDE TWIST DRILL

O SERIES

INTERNAL COOLANT HOLE - 3xD

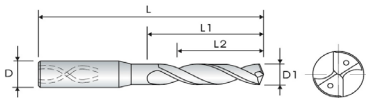

Part number	D1	L2	L1	L	d	H
	Mill Dia.	Max. Drill Depth	Flute Length	Overall Length	Shank Dia.	Helix
ODC-0300-200E11	3.0	17	24	62	6	40
ODC-0310-200E11	3.1	17	24	62	6	40
ODC-0320-200E11	3.2	17	24	62	6	40
ODC-0330-200E11	3.3	17	24	62	6	40
ODC-0340-200E11	3.4	17	24	62	6	40
ODC-0350-200E11	3.5	17	24	62	6	40
ODC-0360-200E11	3.6	17	24	62	6	40
ODC-0370-200E11	3.7	17	24	62	6	40
ODC-0380-240E11	3.8	20	28	66	6	40
ODC-0390-240E11	3.9	20	28	66	6	40
ODC-0400-240E11	4.0	20	28	66	6	40
ODC-0410-240E11	4.1	20	28	66	6	40
ODC-0420-240E11	4.2	20	28	66	6	40
ODC-0430-240E11	4.3	20	28	66	6	40
ODC-0440-240E11	4.4	20	28	66	6	40
ODC-0450-240E11	4.5	20	28	66	6	40
ODC-0460-240E11	4.6	20	28	66	6	30
ODC-0470-240E11	4.7	20	28	66	6	30
ODC-0480-280E11	4.8	20	28	66	6	30
ODC-0490-280E11	4.9	20	28	66	6	30
ODC-0500-280E11	5.0	20	28	66	6	30
ODC-0510-280E11	5.1	20	28	66	6	30
ODC-0520-280E11	5.2	20	28	66	6	30
ODC-0530-280E11	5.3	20	28	66	6	30
ODC-0540-280E11	5.4	20	28	66	6	30

Carbide Drill Bit

● Excellent ○ Good

Carbon Steels	Alloy Steels	Hardened Steels		High Hardened Steels	Copper	Cast iron	Aluminum	Stainless Steels	Titanium	Inconel
~HB225	HB225~325	HRC~50	HRC~55	HRC~60						
	●	●	●					○	○	

CARBIDE TWIST DRILL O SERIES

(CONTINUATION)

INTERNAL COOLANT HOLE - 3xD

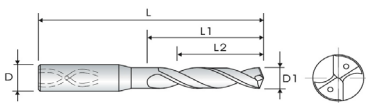

Part number	D1	L2	L1	L	d	H
	Mill Dia.	Max. Drill Depth	Flute Length	Overall Length	Shank Dia.	Helix
ODC-0550-280E11	5.5	20	28	66	6	30
ODC-0560-280E11	5.6	20	28	66	6	30
ODC-0570-280E11	5.7	20	28	66	6	30
ODC-0580-280E11	5.8	20	28	66	6	30
ODC-0590-280E11	5.9	20	28	66	6	30
ODC-0600-280E11	6.0	20	28	66	6	30
ODC-0610-340G11	6.1	29	41	79	8	30
ODC-0620-340G11	6.2	29	41	79	8	30
ODC-0630-340G11	6.3	29	41	79	8	30
ODC-0640-340G11	6.4	29	41	79	8	30
ODC-0650-340G11	6.5	29	41	79	8	30
ODC-0660-340G11	6.6	29	41	79	8	30
ODC-0670-340G11	6.7	29	41	79	8	30
ODC-0680-340G11	6.8	29	41	79	8	30
ODC-0690-340G11	6.9	29	41	79	8	30
ODC-0700-340G11	7.0	29	41	79	8	30
ODC-0710-410G11	7.1	29	41	79	8	30
ODC-0720-410G11	7.2	29	41	79	8	30
ODC-0730-410G11	7.3	29	41	79	8	30
ODC-0740-410G11	7.4	29	41	79	8	30
ODC-0750-410G11	7.5	29	41	79	8	30

Carbide Drill Bit

● Excellent ○ Good

Carbon Steels	Alloy Steels	Hardened Steels		High Hardened Steels	Copper	Cast iron	Aluminum	Stainless Steels	Titanium	Inconel
~HB225	HB225~325	HRC~50	HRC~55	HRC~60						
	●	●	●					○	○	

CARBIDE TWIST DRILL

O SERIES

INTERNAL COOLANT HOLE - 3xD

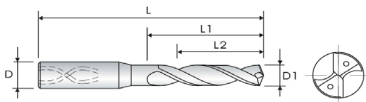

Part number	D1	L2	L1	L	d	H
	Mill Dia.	Max. Drill Depth	Flute Length	Overall Length	Shank Dia.	Helix
ODC-0760-410G11	7.6	29	41	79	8	30
ODC-0770-410G11	7.7	29	41	79	8	30
ODC-0780-410G11	7.8	29	41	79	8	30
ODC-0790-410G11	7.9	29	41	79	8	30
ODC-0800-410G11	8.0	29	41	79	8	30
ODC-0810-470H11	8.1	35	47	89	10	30
ODC-0820-470H11	8.2	35	47	89	10	30
ODC-0830-470H11	8.3	35	47	89	10	30
ODC-0840-470H11	8.4	35	47	89	10	30
ODC-0850-470H11	8.5	35	47	89	10	30
ODC-0860-470H11	8.6	35	47	89	10	30
ODC-0870-470H11	8.7	35	47	89	10	30
ODC-0880-470H11	8.8	35	47	89	10	30
ODC-0890-470H11	8.9	35	47	89	10	30
ODC-0900-470H11	9.0	35	47	89	10	30
ODC-0910-470H11	9.1	35	47	89	10	30
ODC-0920-470H11	9.2	35	47	89	10	30
ODC-0930-470H11	9.3	35	47	89	10	30
ODC-0940-470H11	9.4	35	47	89	10	30
ODC-0950-470H11	9.5	35	47	89	10	30
ODC-0960-470H11	9.6	35	47	89	10	30
ODC-0970-470H11	9.7	35	47	89	10	30
ODC-0980-470H11	9.8	35	47	89	10	30
ODC-0990-470H11	9.9	35	47	89	10	30
ODC-1000-470H11	10.0	35	47	89	10	30

Carbide Drill Bit

● Excellent ○ Good

Carbon Steels	Alloy Steels	Hardened Steels		High Hardened Steels	Copper	Cast iron	Aluminum	Stainless Steels	Titanium	Inconel
~HB225	HB225~325	HRC~50	HRC~55	HRC~60						
	●	●	●					○	○	

CARBIDE TWIST DRILL O SERIES

(CONTINUATION)

INTERNAL COOLANT HOLE - 3xD

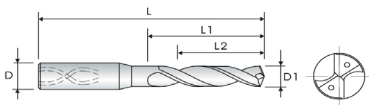

Part number	D1	L2	L1	L	d	H
	Mill Dia.	Max. Drill Depth	Flute Length	Overall Length	Shank Dia.	Helix
ODC-1010-550I11	10.1	40	55	102	12	30
ODC-1020-550I11	10.2	40	55	102	12	30
ODC-1030-550I11	10.3	40	55	102	12	30
ODC-1040-550I11	10.4	40	55	102	12	30
ODC-1050-550I11	10.5	40	55	102	12	30
ODC-1060-550I11	10.6	40	55	102	12	30
ODC-1070-550I11	10.7	40	55	102	12	30
ODC-1080-550I11	10.8	40	55	102	12	30
ODC-1090-550I11	10.9	40	55	102	12	30
ODC-1100-550I11	11.0	40	55	102	12	30
ODC-1110-550I11	11.1	40	55	102	12	30
ODC-1120-550I11	11.2	40	55	102	12	30
ODC-1130-550I11	11.3	40	55	102	12	30
ODC-1140-550I11	11.4	40	55	102	12	30
ODC-1150-550I11	11.5	40	55	102	12	30
ODC-1160-550I11	11.6	40	55	102	12	30
ODC-1170-550I11	11.7	40	55	102	12	30
ODC-1180-550I11	11.8	40	55	102	12	30
ODC-1190-550I11	11.9	40	55	102	12	30
ODC-1200-550I11	12.0	40	55	102	12	30

Carbide Drill Bit

● Excellent ○ Good

Carbon Steels	Alloy Steels	Hardened Steels		High Hardened Steels	Copper	Cast iron	Aluminum	Stainless Steels	Titanium	Inconel
~HB225	HB225~325	HRc~50	HRc~55	HRc~60						
	●	●	●					○	○	

CARBIDE TWIST DRILL O SERIES

INTERNAL COOLANT HOLE -5xD

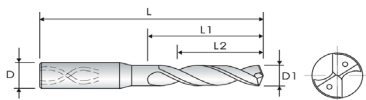

Part number	D1	L2	L1	L	d	H
	Mill Dia.	Max. Drill Depth	Flute Length	Overall Length	Shank Dia.	Helix
ODC-0300-280E11	3.0	23	28	66	6	40
ODC-0310-280E11	3.1	23	28	66	6	40
ODC-0320-280E11	3.2	23	28	66	6	40
ODC-0330-280E11	3.3	23	28	66	6	40
ODC-0340-280E11	3.4	23	28	66	6	40
ODC-0350-280E11	3.5	23	28	66	6	40
ODC-0360-280E11	3.6	23	28	66	6	40
ODC-0370-280E11	3.7	23	28	66	6	40
ODC-0380-360E11	3.8	29	36	74	6	40
ODC-0390-360E11	3.9	29	36	74	6	40
ODC-0400-360E11	4.0	29	36	74	6	40
ODC-0410-360E11	4.1	29	36	74	6	40
ODC-0420-360E11	4.2	29	36	74	6	40
ODC-0430-360E11	4.3	29	36	74	6	40
ODC-0440-360E11	4.4	29	36	74	6	40
ODC-0450-360E11	4.5	29	36	74	6	40
ODC-0460-360E11	4.6	29	36	74	6	30
ODC-0470-360E11	4.7	29	36	74	6	30
ODC-0480-440E11	4.8	35	44	82	6	30
ODC-0490-440E11	4.9	35	44	82	6	30
ODC-0500-440E11	5.0	35	44	82	6	30
ODC-0510-440E11	5.1	35	44	82	6	30
ODC-0520-440E11	5.2	35	44	82	6	30
ODC-0530-440E11	5.3	35	44	82	6	30
ODC-0540-440E11	5.4	35	44	82	6	30

Carbide Drill Bit

● Excellent ○ Good

Carbon Steels	Alloy Steels	Hardened Steels		High Hardened Steels	Copper	Cast iron	Aluminum	Stainless Steels	Titanium	Inconel
~HB225	HB225~325	HRC~50	HRC~55	HRC~60						
	●	●	●					○	○	

CARBIDE TWIST DRILL O SERIES

(CONTINUATION)

INTERNAL COOLANT HOLE -5xD

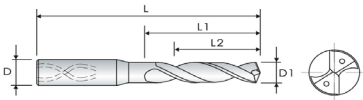

Part number	D1	L2	L1	L	d	H
	Mill Dia.	Max. Drill Depth	Flute Length	Overall Length	Shank Dia.	Helix
ODC-0550-440E11	5.5	35	44	82	6	30
ODC-0560-440E11	5.6	35	44	82	6	30
ODC-0570-440E11	5.7	35	44	82	6	30
ODC-0580-440E11	5.8	35	44	82	6	30
ODC-0590-440E11	5.9	35	44	82	6	30
ODC-0600-440E11	6.0	35	44	82	6	30
ODC-0610-530G11	6.1	43	53	91	8	30
ODC-0620-530G11	6.2	43	53	91	8	30
ODC-0630-530G11	6.3	43	53	91	8	30
ODC-0640-530G11	6.4	43	53	91	8	30
ODC-0650-530G11	6.5	43	53	91	8	30
ODC-0660-530G11	6.6	43	53	91	8	30
ODC-0670-530G11	6.7	43	53	91	8	30
ODC-0680-530G11	6.8	43	53	91	8	30
ODC-0690-530G11	6.9	43	53	91	8	30
ODC-0700-530G11	7.0	43	53	91	8	30
ODC-0710-530G11	7.1	43	53	91	8	30
ODC-0720-530G11	7.2	43	53	91	8	30
ODC-0730-530G11	7.3	43	53	91	8	30
ODC-0740-530G11	7.4	43	53	91	8	30
ODC-0750-530G11	7.5	43	53	91	8	30

Carbide Drill Bit

● Excellent ○ Good

Carbon Steels	Alloy Steels	Hardened Steels		High Hardened Steels	Copper	Cast iron	Aluminum	Stainless Steels	Titanium	Inconel
~HB225	HB225~325	HRc~50	HRc~55	HRc~60						
	●	●	●					○	○	

CARBIDE TWIST DRILL

O SERIES

INTERNAL COOLANT HOLE - 5xD

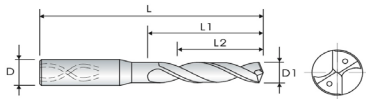

Part number	D1	L2	L1	L	d	H
	Mill Dia.	Max. Drill Depth	Flute Length	Overall Length	Shank Dia.	Helix
ODC-0760-530G11	7.6	43	53	91	8	30
ODC-0770-530G11	7.7	43	53	91	8	30
ODC-0780-530G11	7.8	43	53	91	8	30
ODC-0790-530G11	7.9	43	53	91	8	30
ODC-0800-530G11	8.0	43	53	91	8	30
ODC-0810-610H11	8.1	49	61	103	10	30
ODC-0820-610H11	8.2	49	61	103	10	30
ODC-0830-610H11	8.3	49	61	103	10	30
ODC-0840-610H11	8.4	49	61	103	10	30
ODC-0850-610H11	8.5	49	61	103	10	30
ODC-0860-610H11	8.6	49	61	103	10	30
ODC-0870-610H11	8.7	49	61	103	10	30
ODC-0880-610H11	8.8	49	61	103	10	30
ODC-0890-610H11	8.9	49	61	103	10	30
ODC-0900-610H11	9.0	49	61	103	10	30
ODC-0910-610H11	9.1	49	61	103	10	30
ODC-0920-610H11	9.2	49	61	103	10	30
ODC-0930-610H11	9.3	49	61	103	10	30
ODC-0940-610H11	9.4	49	61	103	10	30
ODC-0950-610H11	9.5	49	61	103	10	30
ODC-0960-610H11	9.6	49	61	103	10	30
ODC-0970-610H11	9.7	49	61	103	10	30
ODC-0980-610H11	9.8	49	61	103	10	30
ODC-0990-610H11	9.9	49	61	103	10	30
ODC-1000-610H11	10.0	49	61	103	10	30

Carbide Drill Bit

● Excellent ○ Good

Carbon Steels	Alloy Steels	Hardened Steels		High Hardened Steels	Copper	Cast iron	Aluminum	Stainless Steels	Titanium	Inconel
~HB225	HB225~325	HRC~50	HRC~55	HRC~60						
	●	●	●					○	○	

CARBIDE TWIST DRILL O SERIES

(CONTINUATION)

INTERNAL COOLANT HOLE - 5xD

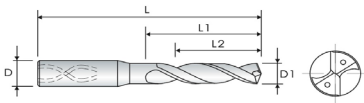

Part number	D1	L2	L1	L	d	H
	Mill Dia.	Max. Drill Depth	Flute Length	Overall Length	Shank Dia.	Helix
ODC-1010-710I11	10.1	56	71	118	12	30
ODC-1020-710I11	10.2	56	71	118	12	30
ODC-1030-710I11	10.3	56	71	118	12	30
ODC-1040-710I11	10.4	56	71	118	12	30
ODC-1050-710I11	10.5	56	71	118	12	30
ODC-1060-710I11	10.6	56	71	118	12	30
ODC-1070-710I11	10.7	56	71	118	12	30
ODC-1080-710I11	10.8	56	71	118	12	30
ODC-1090-710I11	10.9	56	71	118	12	30
ODC-1100-710I11	11.0	56	71	118	12	30
ODC-1110-710I11	11.1	56	71	118	12	30
ODC-1120-710I11	11.2	56	71	118	12	30
ODC-1130-710I11	11.3	56	71	118	12	30
ODC-1140-710I11	11.4	56	71	118	12	30
ODC-1150-710I11	11.5	56	71	118	12	30
ODC-1160-710I11	11.6	56	71	118	12	30
ODC-1170-710I11	11.7	56	71	118	12	30
ODC-1180-710I11	11.8	56	71	118	12	30
ODC-1190-710I11	11.9	56	71	118	12	30
ODC-1200-710I11	12.0	56	71	118	12	30

Carbide Drill Bit

● Excellent ○ Good

Carbon Steels	Alloy Steels	Hardened Steels		High Hardened Steels	Copper	Cast iron	Aluminum	Stainless Steels	Titanium	Inconel
~HB225	HB225~325	HRc~50	HRc~55	HRc~60						
	●	●	●					○	○	

CARBIDE TWIST DRILL

O SERIES

INTERNAL COOLANT HOLE - 8xD

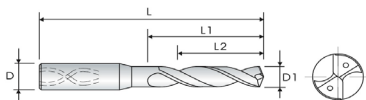

Part number	D1	L2	L1	L	d	H
	Mill Dia.	Max. Drill Depth	Flute Length	Overall Length	Shank Dia.	Helix
ODC-0300-340E11	3.0	29	34	72	6	40
ODC-0310-340E11	3.1	29	34	72	6	40
ODC-0320-340E11	3.2	29	34	72	6	40
ODC-0330-340E11	3.3	29	34	72	6	40
ODC-0340-340E11	3.4	29	34	72	6	40
ODC-0350-340E11	3.5	29	34	72	6	40
ODC-0360-340E11	3.6	29	34	72	6	40
ODC-0370-340E11	3.7	29	34	72	6	40
ODC-0380-430E11	3.8	36	43	81	6	40
ODC-0390-430E11	3.9	36	43	81	6	40
ODC-0400-430E11	4.0	36	43	81	6	40
ODC-0410-430E11	4.1	36	43	81	6	40
ODC-0420-430E11	4.2	36	43	81	6	40
ODC-0430-430E11	4.3	36	43	81	6	40
ODC-0440-430E11	4.4	36	43	81	6	40
ODC-0450-430E11	4.5	36	43	81	6	40
ODC-0460-430E11	4.6	36	43	81	6	30
ODC-0470-570E11	4.7	48	57	95	6	30
ODC-0480-570E11	4.8	48	57	95	6	30
ODC-0490-570E11	4.9	48	57	95	6	30
ODC-0500-570E11	5.0	48	57	95	6	30
ODC-0510-570E11	5.1	48	57	95	6	30
ODC-0520-570E11	5.2	48	57	95	6	30
ODC-0530-570E11	5.3	48	57	95	6	30
ODC-0540-570E11	5.4	48	57	95	6	30

Carbide Drill Bit

● Excellent ○ Good

Carbon Steels	Alloy Steels	Hardened Steels		High Hardened Steels	Copper	Cast iron	Aluminum	Stainless Steels	Titanium	Inconel
~HB225	HB225~325	HRC~50	HRC~55	HRC~60						
	●	●	●					○	○	

CARBIDE TWIST DRILL O SERIES

(CONTINUATION)

INTERNAL COOLANT HOLE - 8xD

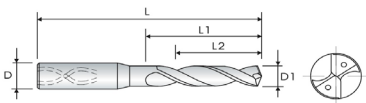

Part number	D1	L2	L1	L	d	H
	Mill Dia.	Max. Drill Depth	Flute Length	Overall Length	Shank Dia.	Helix
ODC-0550-570E11	5.5	48	57	95	6	30
ODC-0560-570E11	5.6	48	57	95	6	30
ODC-0570-570E11	5.7	48	57	95	6	30
ODC-0580-570E11	5.8	48	57	95	6	30
ODC-0590-570E11	5.9	48	57	95	6	30
ODC-0600-570E11	6.0	48	57	95	6	30
ODC-0610-760G11	6.1	64	76	114	8	30
ODC-0620-760G11	6.2	64	76	114	8	30
ODC-0630-760G11	6.3	64	76	114	8	30
ODC-0640-760G11	6.4	64	76	114	8	30
ODC-0650-760G11	6.5	64	76	114	8	30
ODC-0660-760G11	6.6	64	76	114	8	30
ODC-0670-760G11	6.7	64	76	114	8	30
ODC-0680-760G11	6.8	64	76	114	8	30
ODC-0690-760G11	6.9	64	76	114	8	30
ODC-0700-760G11	7.0	64	76	114	8	30
ODC-0710-760G11	7.1	64	76	114	8	30
ODC-0720-760G11	7.2	64	76	114	8	30
ODC-0730-760G11	7.3	64	76	114	8	30
ODC-0740-760G11	7.4	64	76	114	8	30
ODC-0750-760G11	7.5	64	76	114	8	30

Carbide Drill Bit

● Excellent ○ Good

Carbon Steels	Alloy Steels	Hardened Steels		High Hardened Steels	Copper	Cast iron	Aluminum	Stainless Steels	Titanium	Inconel
~HB225	HB225~325	HRc~50	HRc~55	HRc~60						
	●	●	●					○	○	

CARBIDE TWIST DRILL O SERIES

INTERNAL COOLANT HOLE - 8xD

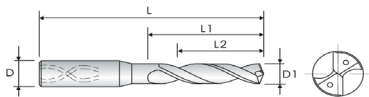

Part number	D1	L2	L1	L	d	H
	Mill Dia.	Max. Drill Depth	Flute Length	Overall Length	Shank Dia.	Helix
ODC-0760-760G11	7.6	64	76	114	8	30
ODC-0770-760G11	7.7	64	76	114	8	30
ODC-0780-760G11	7.8	64	76	114	8	30
ODC-0790-760G11	7.9	64	76	114	8	30
ODC-0800-760G11	8.0	64	76	114	8	30
ODC-0810-950H11	8.1	80	95	142	10	30
ODC-0820-950H11	8.2	80	95	142	10	30
ODC-0830-950H11	8.3	80	95	142	10	30
ODC-0840-950H11	8.4	80	95	142	10	30
ODC-0850-950H11	8.5	80	95	142	10	30
ODC-0860-950H11	8.6	80	95	142	10	30
ODC-0870-950H11	8.7	80	95	142	10	30
ODC-0880-950H11	8.8	80	95	142	10	30
ODC-0890-950H11	8.9	80	95	142	10	30
ODC-0900-950H11	9.0	80	95	142	10	30
ODC-0910-950H11	9.1	80	95	142	10	30
ODC-0920-950H11	9.2	80	95	142	10	30
ODC-0930-950H11	9.3	80	95	142	10	30
ODC-0940-950H11	9.4	80	95	142	10	30
ODC-0950-950H11	9.5	80	95	142	10	30
ODC-0960-950H11	9.6	80	95	142	10	30
ODC-0970-950H11	9.7	80	95	142	10	30
ODC-0980-950H11	9.8	80	95	142	10	30
ODC-0990-950H11	9.9	80	95	142	10	30
ODC-1000-950H11	10.0	80	95	142	10	30

Carbide Drill Bit

● Excellent ○ Good

Carbon Steels	Alloy Steels	Hardened Steels		High Hardened Steels	Copper	Cast iron	Aluminum	Stainless Steels	Titanium	Inconel
~HB225	HB225~325	HRC~50	HRC~55	HRC~60						
	●	●	●					○	○	

CARBIDE TWIST DRILL O SERIES

(CONTINUATION)

INTERNAL COOLANT HOLE - 8xD

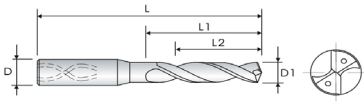

Part number	D1	L2	L1	L	d	H
	Mill Dia.	Max. Drill Depth	Flute Length	Overall Length	Shank Dia.	Helix
ODC-1010-114 11	10.1	96	114	162	12	30
ODC-1020-114 11	10.2	96	114	162	12	30
ODC-1030-114 11	10.3	96	114	162	12	30
ODC-1040-114 11	10.4	96	114	162	12	30
ODC-1050-114 11	10.5	96	114	162	12	30
ODC-1060-114 11	10.6	96	114	162	12	30
ODC-1070-114 11	10.7	96	114	162	12	30
ODC-1080-114 11	10.8	96	114	162	12	30
ODC-1090-114 11	10.9	96	114	162	12	30
ODC-1100-114 11	11.0	96	114	162	12	30
ODC-1110-114 11	11.1	96	114	162	12	30
ODC-1120-114 11	11.2	96	114	162	12	30
ODC-1130-114 11	11.3	96	114	162	12	30
ODC-1140-114 11	11.4	96	114	162	12	30
ODC-1150-114 11	11.5	96	114	162	12	30
ODC-1160-114 11	11.6	96	114	162	12	30
ODC-1170-114 11	11.7	96	114	162	12	30
ODC-1180-114 11	11.8	96	114	162	12	30
ODC-1190-114 11	11.9	96	114	162	12	30
ODC-1200-114 11	12.0	96	114	162	12	30

Carbide Drill Bit

● Excellent ○ Good

Carbon Steels	Alloy Steels	Hardened Steels		High Hardened Steels	Copper	Cast iron	Aluminum	Stainless Steels	Titanium	Inconel
~HB225	HB225~325	HRc~50	HRc~55	HRc~60						
	●	●	●					○	○	

CARBIDE MINIATURE BORING O SERIES

FRONT BORING FOR EASY CUTTING

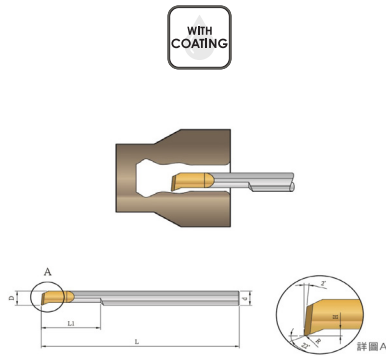

Part number	D1	L1	H	R	L	d
	Mill Dia.	Flute Length			Overall Length	Shank Dia.
OOE-0100-060B11	1.0	6	0.2	0.05	50	3
OOE-0150-060B11	1.5	6	0.3	0.05	50	3
OOE-0200-080B11	2.0	8	0.5	0.05	50	3
OOE-0250-080B11	2.5	8	0.5	0.05	50	3
OOE-0300-100B11	3.0	10	0.7	0.1	50	3
OOE-0350-100C11	3.5	10	0.7	0.1	50	4
OOE-0400-150C11	4.0	15	0.8	0.1	50	4
OOE-0450-150E11	4.5	15	0.8	0.1	50	6
OOE-0500-150E11	5.0	15	1.2	0.1	50	6
OOE-0550-180E11	5.5	18	1.2	0.1	50	6
OOE-0600-180E11	6.0	18	1.4	0.1	50	6
OOE-0700-200G11	7.0	20	1.5	0.2	60	8
OOE-0800-220G11	8.0	22	1.5	0.2	60	8

FRONT BORING FOR HEAVY CUTTING

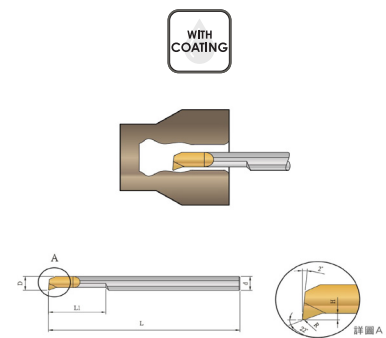

Part number	D1	L1	H	R	L	d
	Mill Dia.	Flute Length			Overall Length	Shank Dia.
OOM-0100-060B11	1.0	6	0.2	0.05	50	3
OOM-0150-060B11	1.5	6	0.3	0.05	50	3
OOM-0200-080B11	2.0	8	0.5	0.05	50	3
OOM-0250-080B11	2.5	8	0.5	0.05	50	3
OOM-0300-100B11	3.0	10	0.7	0.1	50	3
OOM-0350-100C11	3.5	10	0.7	0.1	50	4
OOM-0400-150C11	4.0	15	0.8	0.1	50	4
OOM-0450-150E11	4.5	15	0.8	0.1	50	6
OOM-0500-150E11	5.0	15	1.2	0.1	50	6
OOM-0550-180E11	5.5	18	1.2	0.1	50	6
OOM-0600-180E11	6.0	18	1.4	0.1	50	6
OOM-0700-200G11	7.0	20	1.5	0.2	60	8
OOM-0800-220G11	8.0	22	1.5	0.2	60	8

Carbide Drill Bit

● Excellent ○ Good

Carbon Steels	Alloy Steels	Hardened Steels		High Hardened Steels	Copper	Cast iron	Aluminum	Stainless Steels	Titanium	Inconel
~HB225	HB225~325	HRC~50	HRC~55	HRC~60						
●	●						●	○		

CARBIDE MINIATURE BORING O SERIES

FRONT BORING 45° BACK

Chamfer Angle

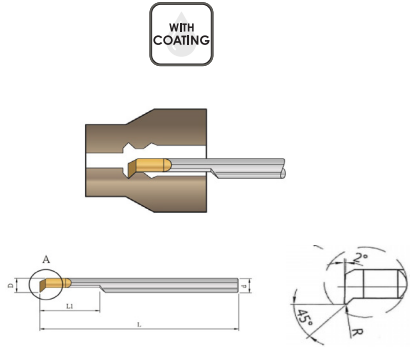

Part number	D1	L1	H	R	L	d
	Mill Dia.	Flute Length			Overall Length	Shank Dia.
OOC-0100-060B11	1.0	6	0.2	0.05	50	3
OOC-0150-060B11	1.5	6	0.3	0.05	50	3
OOC-0200-080B11	2.0	8	0.5	0.05	50	3
OOC-0250-080B11	2.5	8	0.5	0.05	50	3
OOC-0300-100B11	3.0	10	0.7	0.1	50	3
OOC-0350-100C11	3.5	10	0.7	0.1	50	4
OOC-0400-150C11	4.0	15	0.8	0.1	50	4
OOC-0450-150E11	4.5	15	0.8	0.1	50	6
OOC-0500-150E11	5.0	15	1.2	0.1	50	6
OOC-0550-180E11	5.5	18	1.2	0.1	50	6
OOC-0600-180E11	6.0	18	1.4	0.1	50	6
OOC-0700-200G11	7.0	20	1.5	0.2	60	8
OOC-0800-220G11	8.0	22	1.5	0.2	60	8

FRONT BORING 90°

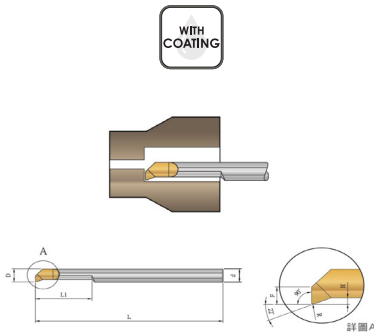

Part number	D	F	FL	H	R	SL	SD
	Mill Dia.		Flute Length			Overall Length	Shank Dia.
OO9-0100-060B11	1.0	0.50	6	0.2	0.05	50	3
OO9-0150-060B11	1.5	0.75	6	0.3	0.05	50	3
OO9-0200-080B11	2.0	1.00	8	0.5	0.05	50	3
OO9-0250-080B11	2.5	1.25	8	0.5	0.05	50	3
OO9-0300-100B11	3.0	1.50	10	0.7	0.1	50	3
OO9-0350-100C11	3.5	1.75	10	0.7	0.1	50	4
OO9-0400-150C11	4.0	2.00	15	0.8	0.1	50	4
OO9-0450-150E11	4.5	2.25	15	0.8	0.1	50	6
OO9-0500-150E11	5.0	2.50	15	1.2	0.15	50	6
OO9-0550-180E11	5.5	2.75	18	1.2	0.15	50	6
OO9-0600-180E11	6.0	3.00	18	1.4	0.15	50	6
OO9-0700-200G11	7.0	3.50	20	1.5	0.2	60	8
OO9-0800-220G11	8.0	4.00	22	1.5	0.2	60	8

Carbide Drill Bit

● Excellent ○ Good

Carbon Steels	Alloy Steels	Hardened Steels		High Hardened Steels	Copper	Cast iron	Aluminum	Stainless Steels	Titanium	Inconel
~HB225	HB225~325	HRC~50	HRC~55	HRC~60						
●	●						●	○		

CARBIDE MINIATURE BORING O SERIES

FRONT BORING FOR COPPER

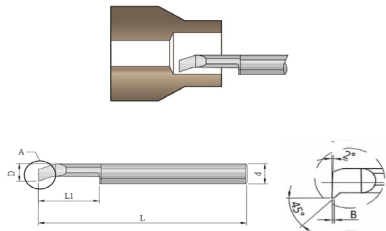

Part number	D1	L1	H	B	L	d
	Mill Dia.	Flute Length			Overall Length	Shank Dia.
OOX-0100-060B11	1.0	6	0.2	0.2	50	3
OOX-0150-060B11	1.5	6	0.3	0.2	50	3
OOX-0200-080B11	2.0	8	0.5	0.2	50	3
OOX-0250-080B11	2.5	8	0.5	0.2	50	3
OOX-0300-100B11	3.0	10	0.7	0.2	50	3
OOX-0350-100C11	3.5	10	0.7	0.2	50	4
OOX-0400-150C11	4.0	15	0.8	0.2	50	4
OOX-0450-150E11	4.5	15	0.8	0.4	50	6
OOX-0500-150R11	5.0	15	1.2	0.2	50	6
OOX-0500-150R21	5.0	15	1.2	0.4	50	6
OOX-0550-180R11	5.5	18	1.2	0.2	50	6
OOX-0550-180R21	5.5	18	1.2	0.4	50	6
OOX-0600-180E11	6.0	18	1.4	0.4	50	6

FRONT BORING 45° BACK

Chamfer Angle for Copper

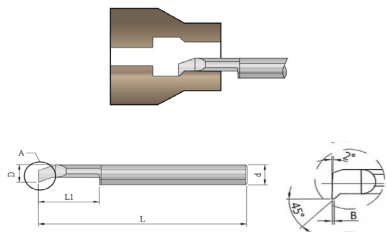

Part number	D1	L1	H	B	L	d
	Mill Dia.	Flute Length			Overall Length	Shank Dia.
OOB-0100-060B11	1.0	6	0.2	0.2	50	3
OOB-0150-060B11	1.5	6	0.3	0.2	50	3
OOB-0200-080B11	2.0	8	0.5	0.2	50	3
OOB-0250-080B11	2.5	8	0.5	0.2	50	3
OOB-0300-100B11	3.0	10	0.7	0.2	50	3
OOB-0350-100C11	3.5	10	0.7	0.2	50	4
OOB-0400-150C11	4.0	15	0.8	0.2	50	4
OOB-0450-150E11	4.5	15	0.8	0.4	50	6
OOB-0500-150E11	5.0	15	1.2	0.4	50	6
OOB-0550-180E11	5.5	18	1.2	0.4	50	6
OOB-0600-180E11	6.0	18	1.4	0.4	50	6

Carbide Drill Bit

● Excellent ○ Good

Carbon Steels	Alloy Steels	Hardened Steels		High Hardened Steels	Copper	Cast iron	Aluminum	Stainless Steels	Titanium	Inconel
~HB225	HB225~325	HRC~50	HRC~55	HRC~60						
●	●						●	○		

CARBIDE MINIATURE BORING O SERIES

GROOVING

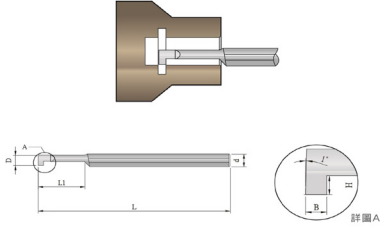

Part number	D1	L1	H	B	L	d
	Mill Dia.	Flute Length			Overall Length	Shank Dia.
OOG-0100-040B11	1.0	4	0.3	0.35	50	3
OOG-0150-060B11	1.5	6	0.3	0.35	50	3
OOG-0185-080B11	1.85	8	0.5	0.5	50	3
OOG-0200-080B11	2.0	8	0.5	0.5	50	3
OOG-0250-080B11	2.5	8	0.5	0.5	50	3
OOG-0300-080B11	3.0	8	0.7	0.5	50	3
OOG-0350-120C11	3.5	12	0.7	0.8	50	4
OOG-0400-120C11	4.0	12	1.0	0.8	50	4
OOG-0450-150E11	4.5	15	1.0	1.0	50	6
OOG-0500-150E11	5.0	15	1.0	1.0	50	6
OOG-0550-150E11	5.5	15	1.0	1.0	50	6
OOG-0600-150E11	6.0	15	1.0	1.0	50	6
OOX-0600-180E11	6.0	18	1.4	0.4	50	6

Carbide Drill Bit

● Excellent ○ Good

Carbon Steels	Alloy Steels	Hardened Steels		High Hardened Steels	Copper	Cast iron	Aluminum	Stainless Steels	Titanium	Inconel
~HB225	HB225~325	HRC~50	HRC~55	HRC~60						
●	●						●	○		

CARBIDE FRONT END FASTENING O SERIES

FRONT BORING FOR COPPER

Treading

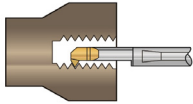

Part number	D1	L1	H	R	L	d	P
	Mill Dia.	Flute Length			Overall Length	Shank Dia.	
OOT-0240-080B11	2.4	8	0.7	0.05	38	3	0.8
OOT-0300-150B11	3.0	15	0.85	0.05	38	3	1.0
OOT-0400-150C11	4.0	15	0.85	0.05	38	4	1.0
OOT-0500-150E11	5.0	15	1.1	0.08	38	6	1.5
OOT-0600-150E11	6.0	15	1.1	0.08	38	6	1.5

Carbide Drill Bit

● Excellent ○ Good

Carbon Steels	Alloy Steels	Hardened Steels		High Hardened Steels	Copper	Cast iron	Aluminum	Stainless Steels	Titanium	Inconel
~HB225	HB225~325	HRC~50	HRC~55	HRC~60						
●	●						●	○		

CARBIDE FRONT END FASTENING O SERIES



FRONT BORING FOR EASY CUTTING

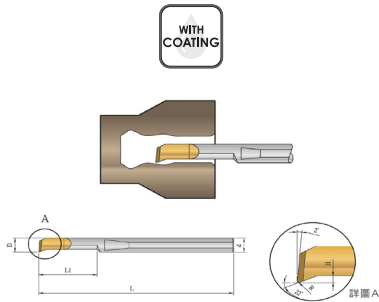

Part number	D1	L1	H	R	L	d
	Mill Dia.	Flute Length			Overall Length	Shank Dia.
OOF-0100-060B11	1.0	6	0.2	0.05	38	3
OOF-0150-060B11	1.5	6	0.3	0.05	38	3
OOF-0200-080B11	2.0	8	0.5	0.05	38	3
OOF-0250-080B11	2.5	8	0.5	0.05	38	3
OOF-0300-100B11	3.0	10	0.7	0.1	38	3
OOF-0350-100C11	3.5	10	0.7	0.1	38	4
OOF-0400-150C11	4.0	15	0.8	0.1	38	4
OOF-0450-150E11	4.5	15	0.8	0.1	38	6
OOF-0500-150E11	5.0	15	1.2	0.1	38	6
OOF-0550-180E11	5.5	18	1.2	0.1	38	6
OOF-0600-180E11	6.0	18	1.4	0.1	38	6
OOF-0700-200G11	7.0	20	1.5	0.2	45	8
OOF-0800-220G11	8.0	22	1.5	0.2	45	8

FRONT BORING FOR HEAVY CUTTING

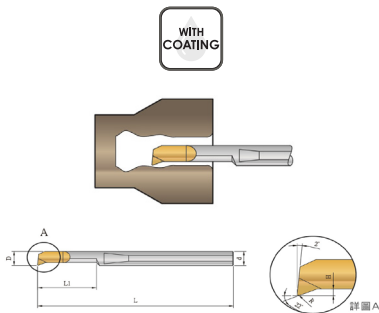

Part number	D1	L1	H	R	L	d
	Mill Dia.	Flute Length			Overall Length	Shank Dia.
OOH-0100-060B11	1.0	6	0.2	0.05	38	3
OOH-0150-060B11	1.5	6	0.3	0.05	38	3
OOH-0200-080B11	2.0	8	0.5	0.05	38	3
OOH-0250-080B11	2.5	8	0.5	0.05	38	3
OOH-0300-100B11	3.0	10	0.7	0.1	38	3
OOH-0350-100C11	3.5	10	0.7	0.1	38	4
OOH-0400-150C11	4.0	15	0.8	0.1	38	4
OOH-0450-150E11	4.5	15	0.8	0.1	38	6
OOH-0500-150E11	5.0	15	1.2	0.1	38	6
OOH-0550-180E11	5.5	18	1.2	0.1	38	6
OOH-0600-180E11	6.0	18	1.4	0.1	38	6
OOH-0700-200G11	7.0	20	1.5	0.2	45	8
OOH-0800-220G11	8.0	22	1.5	0.2	45	8

Carbide Drill Bit

● Excellent ○ Good

Carbon Steels	Alloy Steels	Hardened Steels		High Hardened Steels	Copper	Cast iron	Aluminum	Stainless Steels	Titanium	Inconel
~HB225	HB225~325	HRC~50	HRC~55	HRC~60						
●	●						●	○		

CARBIDE MINIATURE BORING O SERIES

TREADING

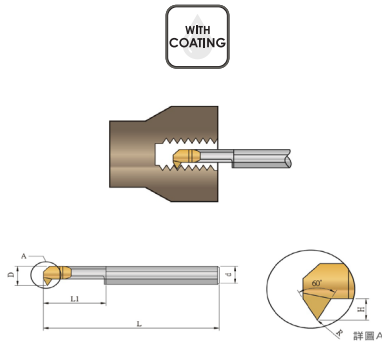

Part number	D1	L1	H	R	L	d	P
	Mill Dia.	Flute Length			Overall Length	Shank Dia.	
OOR-0240-080B11	2.4	8	0.7	0.05	50	3	0.8
OOR-0300-150B11	3.0	15	0.85	0.05	50	3	1.0
OOR-0400-150C11	4.0	15	0.85	0.05	50	4	1.0
OOR-0500-150E11	5.0	15	1.1	0.08	50	6	1.5
OOR-0600-150E11	6.0	15	1.1	0.08	50	6	1.5

GROOVING R ITEM

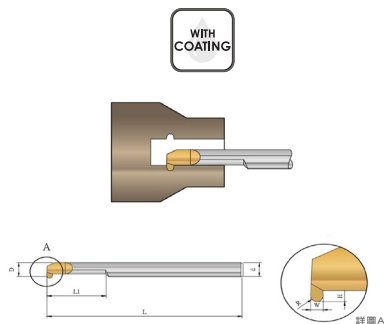

Part number	D1	L1	H	R	W	L	d
	Mill Dia.	Flute Length				Overall Length	Shank Dia.
OOC-0400-100R11	4.0	10	1	0.5	1	50	4
OOC-0400-100R21	4.0	10	1	0.75	1.5	50	4
OOC-0500-150R11	5.0	15	1.2	0.5	1	50	6
OOC-0500-150R21	5.0	15	1.2	0.75	1.5	50	6
OOC-0500-150R31	5.0	15	1.2	1	2	50	6
OOC-0600-150R11	6.0	15	1.6	0.5	1	50	6
OOC-0600-150R21	6.0	15	1.6	0.75	1.5	50	6
OOC-0600-150R31	6.0	15	1.6	1	2	50	6

Carbide Drill Bit

● Excellent ○ Good

Carbon Steels	Alloy Steels	Hardened Steels		High Hardened Steels	Copper	Cast iron	Aluminum	Stainless Steels	Titanium	Inconel
~HB225	HB225~325	HRC~50	HRC~55	HRC~60						
●	●						●	○		

CARBIDE MINIATURE BORING O SERIES

SLOTTING

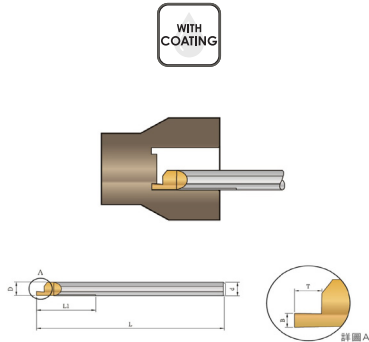

Part number	D1	L1	B	T	L	d
	Mill Dia.				Overall Length	Shank Dia.
OOS-0400-150R11	4.0	15	0.75	1.2	50	4
OOS-0400-150R21	4.0	15	1	1.5	50	4
OOS-0500-220R11	5.0	22	0.75	1.2	50	6
OOS-0500-220R21	5.0	22	1	1.5	50	6
OOS-0500-220R31	5.0	22	1.5	2.5	50	6
OOS-0600-220R11	6.0	22	1	1.5	50	6
OOS-0600-220R21	6.0	22	1.5	2.5	50	6
OOS-0600-220R31	6.0	22	2	3	50	6
OOS-0800-220R11	8.0	22	2.5	3.5	60	8

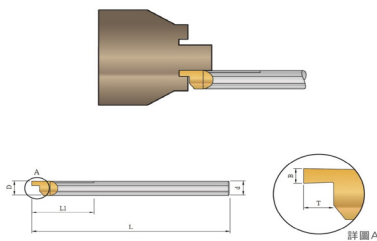

Part number	D1	L1	B	T	L	d
	Mill Dia.				Overall Length	Shank Dia.
OOS-0400-150R11	4.0	15	0.75	1.2	50	4
OOS-0400-150R21	4.0	15	1	1.5	50	4
OOS-0500-220R11	5.0	22	0.75	1.2	50	6
OOS-0500-220R21	5.0	22	1	1.5	50	6
OOS-0500-220R31	5.0	22	1.5	2.5	50	6
OOS-0600-220R11	6.0	22	1	1.5	50	6
OOS-0600-220R21	6.0	22	1.5	2.5	50	6
OOS-0600-220R31	6.0	22	2	3	50	6
OOS-0800-220R11	8.0	22	2.5	3.5	60	8

SLOTTING - R ITEM

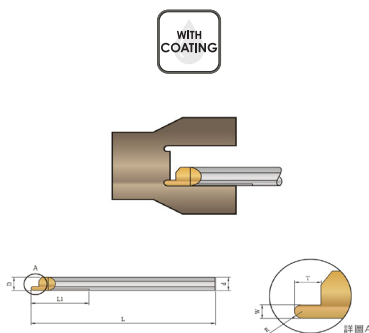

Part number	D1	L1	R	W	T	L	d
	Mill Dia.	Flute Length				Overall Length	Shank Dia.
OOC-0400-150R11	4.0	15	0.50	1.0	1.2	50	4
OOC-0400-150R21	4.0	15	0.75	1.5	1.5	50	4
OOC-0500-220R11	5.0	22	0.50	1.0	1.2	50	6
OOC-0500-220R21	5.0	22	0.75	1.5	1.5	50	6
OOC-0500-220R31	5.0	22	1.00	2.0	2.5	50	6
OOC-0600-220R11	6.0	22	0.50	1.0	1.2	50	6
OOC-0600-220R21	6.0	22	0.75	1.5	1.5	50	6
OOC-0600-220R31	6.0	22	1.00	2.0	2.5	50	6

Carbide Drill Bit

● Excellent ○ Good

Carbon Steels	Alloy Steels	Hardened Steels		High Hardened Steels	Copper	Cast iron	Aluminum	Stainless Steels	Titanium	Inconel
~HB225	HB225~325	HRC~50	HRC~55	HRC~60						
●	●						●	○		

CARBIDE CHAMFER O SERIES

CARBIDE CHAMFER

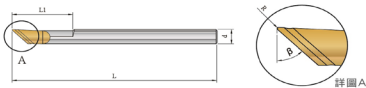
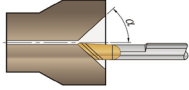

Part number	L1	R	α	β	SL	SD
					Overall Length	Shank Dia.
OOC-6030-150E11	15.0	0.2	60°	30°	50	6
OOC-4545-150E11	15.0	0.2	45°	45°	50	6
OOC-3060-150E11	15.0	0.2	30°	60°	50	6

Carbide Drill Bit

● Excellent ○ Good

Carbon Steels	Alloy Steels	Hardened Steels		High Hardened Steels	Copper	Cast iron	Aluminum	Stainless Steels	Titanium	Inconel
~HB225	HB225~325	HRC~50	HRC~55	HRC~60						
●	●						●	○		

MINIATURE BORING HOLDER O SERIES

INTERNAL COOLANT HOLE

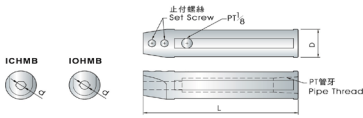

Part number	D1	PT	L	d
			Overall Length	Shank Dia.
OOX-PT18-030J11	3	PT 1/8	100	16
OOX-PT18-040J11	4	PT 1/8	100	16
OOX-PT18-050J11	5	PT 1/8	100	16
OOX-PT18-060J11	6	PT 1/8	100	16
OOX-PT14-030P11	3	PT 1/4	90	19.05
OOX-PT14-040P11	4	PT 1/4	90	19.05
OOX-PT14-050P11	5	PT 1/4	90	19.05
OOX-PT14-060P11	6	PT 1/4	90	19.05
OOX-PT14-080P11	8	PT 1/4	90	19.05
OOX-PT14-030K11	3	PT 1/4	100	20
OOX-PT14-040K11	4	PT 1/4	100	20
OOX-PT14-050K11	5	PT 1/4	100	20
OOX-PT14-060K11	6	PT 1/4	100	20
OOX-PT14-080K11	8	PT 1/4	100	20
OOX-PT38-030L11	3	PT 3/8	100	22
OOX-PT38-040L11	4	PT 3/8	100	22
OOX-PT38-050L11	5	PT 3/8	100	22
OOX-PT38-060L11	6	PT 3/8	100	22
OOX-PT38-080L11	8	PT 3/8	100	22
OOX-PT38-030M11	3	PT 3/8	100	23
OOX-PT38-040M11	4	PT 3/8	100	23
OOX-PT38-050M11	5	PT 3/8	100	23
OOX-PT38-060M11	6	PT 3/8	100	23

Carbide Drill Bit

● Excellent ○ Good

Carbon Steels	Alloy Steels	Hardened Steels		High Hardened Steels	Copper	Cast iron	Aluminum	Stainless Steels	Titanium	Inconel
~HB225	HB225~325	HRc~50	HRc~55	HRc~60						
●	●						●	○		

MINIATURE BORING HOLDER O SERIES

(CONTINUATION)

INTERNAL COOLANT HOLE

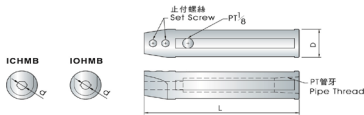

Part number	D1	PT	L	d
			Overall Length	Shank Dia.
OOX-PT38-080M11	8	PT 3/8	100	23
OOX-PT38-030N11	3	PT 3/8	100	25
OOX-PT38-040N11	4	PT 3/8	100	25
OOX-PT38-050N11	5	PT 3/8	100	25
OOX-PT38-060N11	6	PT 3/8	100	25
OOX-PT38-080N11	8	PT 3/8	100	25
OOX-PT38-030P11	3	PT 3/8	80	25.4
OOX-PT38-040P11	4	PT 3/8	80	25.4
OOX-PT38-050P11	5	PT 3/8	80	25.4
OOX-PT38-060P11	6	PT 3/8	80	25.4
OOX-PT38-080P11	8	PT 3/8	80	25.4
OOX-PT38-060O11	6	PT 3/8	125	32
OOX-PT38-080O11	8	PT 3/8	125	32

Carbide Drill Bit

● Excellent ○ Good

Carbon Steels	Alloy Steels	Hardened Steels		High Hardened Steels	Copper	Cast iron	Aluminum	Stainless Steels	Titanium	Inconel
~HB225	HB225~325	HRC~50	HRC~55	HRC~60						
●	●						●	○		

INTERNAL COOLANT HOLE FOR MACHINING ON BACK SIDE

Part number	D1
OOX-0000-030Q11	3.0
OOX-0000-040Q11	4.0
OOX-0000-050Q11	5.0
OOX-0000-060Q11	6.0
OOX-0000-080Q11	8.0

ICBMB

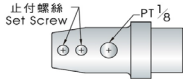
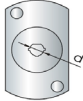

ICBMN

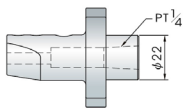
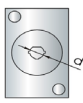

Carbide Drill Bit

● Excellent ○ Good

Carbon Steels	Alloy Steels	Hardened Steels		High Hardened Steels	Copper	Cast iron	Aluminum	Stainless Steels	Titanium	Inconel
~HB225	HB225~325	HRc~50	HRc~55	HRc~60						
●	●						●	○		

CARBIDE REAMER O SERIES

STANDARD

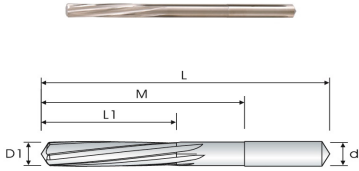

Part number	D1	L1	M	L	d	F
	Mill Dia.	Flute Length	Length under Shank	Overall Length	Shank Dia.	No. of Flute
OOX-0100-140P31	1.0	5.5	14	36	1.0	3
OOX-0110-140P31	1.1	6.5	14	36	1.1	3
OOX-0120-140P31	1.2	7.5	14	36	1.2	3
OOX-0130-140P31	1.3	7.5	14	36	1.3	3
OOX-0140-160P31	1.4	8	16	43	1.4	3
OOX-0150-160P31	1.5	8	16	43	1.5	3
OOX-0160-160P31	1.6	9	16	43	1.6	3
OOX-0170-160P31	1.7	9	16	43	1.7	3
OOX-0180-200P31	1.8	10	20	49	1.8	3
OOX-0190-200P31	1.9	10	20	49	1.9	3
OOX-0200-220P41	2.0	11	22	49	2.0	4
OOX-0210-280P41	2.1	14	28	49	2.1	4
OOX-0220-280P41	2.2	14	28	57	2.2	4
OOX-0230-280P41	2.3	14	28	57	2.3	4
OOX-0240-280P41	2.4	14	28	57	2.4	4
OOX-0250-280P41	2.5	14	28	57	2.5	4
OOX-0260-280P41	2.6	14	28	57	2.6	4
OOX-0270-300P41	2.7	15	30	61	2.7	4
OOX-0280-300P41	2.8	15	30	61	2.8	4
OOX-0290-300P41	2.9	15	30	61	2.9	4
OOX-0300-300P41	3.0	15	30	61	3.0	4
OOX-0310-330P41	3.1	16	33	65	3.1	4
OOX-0320-330P41	3.2	16	33	65	3.2	4
OOX-0330-330P41	3.3	16	33	65	3.3	4
OOX-0340-390P41	3.4	18	39	70	3.4	4

Carbide Drill Bit

● Excellent ○ Good

Carbon Steels	Alloy Steels	Hardened Steels		High Hardened Steels	Copper	Cast iron	Aluminum	Stainless Steels	Titanium	Inconel
~HB225	HB225~325	HRC~50	HRC~55	HRC~60						
●	●						●	○		

CARBIDE REAMER O SERIES

(CONTINUATION)

STANDARD

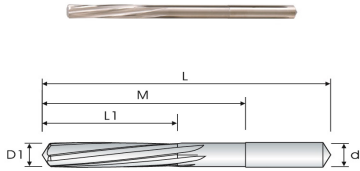

Part number	D1	L1	M	L	d	F
	Mill Dia.	Flute Length	Length under Shank	Overall Length	Shank Dia.	No. of Flute
OOX-0350-390P41	3.5	18	39	70	3.5	4
OOX-0360-390P41	3.6	18	39	70	3.6	4
OOX-0370-390P41	3.7	18	39	70	3.7	4
OOX-0380-390P41	3.8	18	39	70	3.8	4
OOX-0390-440P41	3.9	19	44	75	3.9	4
OOX-0400-440P61	4.0	19	44	75	4.0	6
OOX-0410-440P61	4.1	19	44	75	4.1	6
OOX-0420-440P61	4.2	19	44	75	4.2	6
OOX-0430-490P61	4.3	21	49	80	4.3	6
OOX-0440-490P61	4.4	21	49	80	4.4	6
OOX-0450-490P61	4.5	21	49	80	4.5	6
OOX-0460-490P61	4.6	21	49	80	4.6	6

Carbide Drill Bit

● Excellent ○ Good

Carbon Steels	Alloy Steels	Hardened Steels		High Hardened Steels	Copper	Cast iron	Aluminum	Stainless Steels	Titanium	Inconel
~HB225	HB225~325	HRc~50	HRc~55	HRc~60						
●	●						●	○		

CARBIDE REAMER O SERIES

STANDARD

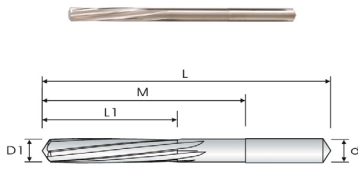

Part number	D1	L1	M	L	d	F
	Mill Dia.	Flute Length	Length under Shank	Overall Length	Shank Dia.	No. of Flute
OOX-0470-490P61	4.7	21	49	80	4.7	6
OOX-0480-550P61	4.8	23	55	86	4.8	6
OOX-0490-550P61	4.9	23	55	86	4.9	6
OOX-0500-550P61	5.0	23	55	86	5.0	6
OOX-0510-550P61	5.1	23	55	86	5.1	6
OOX-0520-550P61	5.2	23	55	86	5.2	6
OOX-0530-610P61	5.3	26	61	86	5.3	6
OOX-0540-610P61	5.4	26	61	93	5.4	6
OOX-0550-610P61	5.5	26	61	93	5.5	6
OOX-0560-610P61	5.6	26	61	93	5.6	6
OOX-0570-610P61	5.7	26	61	93	5.7	6
OOX-0580-610P61	5.8	26	61	93	5.8	6
OOX-0590-610P61	5.9	26	61	93	5.9	6
OOX-0600-610P61	6.0	26	61	93	6.0	6
OOX-0610-700P61	6.1	28	70	101	6.1	6
OOX-0620-700P61	6.2	28	70	101	6.2	6
OOX-0630-700P61	6.3	28	70	101	6.3	6
OOX-0640-700P61	6.4	28	70	101	6.4	6
OOX-0650-700P61	6.5	28	70	101	6.5	6
OOX-0660-700P61	6.6	28	70	101	6.6	6
OOX-0670-700P61	6.7	28	70	101	6.7	6
OOX-0680-770P61	6.8	31	77	109	6.8	6
OOX-0690-770P61	6.9	31	77	109	6.9	6
OOX-0700-770P61	7.0	31	77	109	7.0	6
OOX-0710-770P61	7.1	31	77	109	7.1	6

Carbide Drill Bit

● Excellent ○ Good

Carbon Steels	Alloy Steels	Hardened Steels		High Hardened Steels	Copper	Cast iron	Aluminum	Stainless Steels	Titanium	Inconel
~HB225	HB225~325	HRC~50	HRC~55	HRC~60						
●	●						●	○		

CARBIDE REAMER O SERIES

(CONTINUATION)

STANDARD

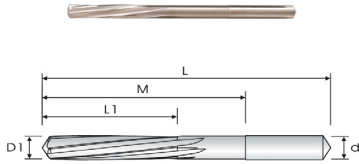

Part number	D1	L1	M	L	d	F
	Mill Dia.	Flute Length	Length under Shank	Overall Length	Shank Dia.	No. of Flute
OOX-0720-770P61	7.2	31	77	109	7.2	6
OOX-0730-770P61	7.3	31	77	109	7.3	6
OOX-0740-770P61	7.4	31	77	109	7.4	6
OOX-0750-770P61	7.5	31	77	109	7.5	6
OOX-0760-770P61	7.6	31	77	109	7.6	6
OOX-0770-800P61	7.7	33	80	117	7.7	6
OOX-0780-800P61	7.8	33	80	117	7.8	6
OOX-0790-800P61	7.9	33	80	117	7.9	6
OOX-0800-800P61	8.0	33	80	117	8.0	6
OOX-0810-800P61	8.1	33	80	117	8.1	6
OOX-0820-800P61	8.2	33	80	117	8.2	6
OOX-0830-800P61	8.3	33	80	117	8.3	6

Carbide Drill Bit

● Excellent ○ Good

Carbon Steels	Alloy Steels	Hardened Steels		High Hardened Steels	Copper	Cast iron	Aluminum	Stainless Steels	Titanium	Inconel
~HB225	HB225~325	HRc~50	HRc~55	HRc~60						
●	●						●	○		

CARBIDE REAMER O SERIES

STANDARD

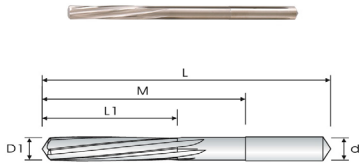

Part number	D1	L1	M	L	d	F
	Mill Dia.	Flute Length	Length under Shank	Overall Length	Shank Dia.	No. of Flute
OOX-0840-800P61	8.4	33	80	117	8.4	6
OOX-0850-800P61	8.5	33	80	117	8.5	6
OOX-0860-800P61	8.6	33	80	117	8.6	6
OOX-0870-900P61	8.7	36	90	125	8.7	6
OOX-0880-900P61	8.8	36	90	125	8.8	6
OOX-0890-900P61	8.9	36	90	125	8.9	6
OOX-0900-900P61	9.0	36	90	125	9.0	6
OOX-0910-900P61	9.1	36	90	125	9.1	6
OOX-0920-900P61	9.2	36	90	125	9.2	6
OOX-0930-900P61	9.3	36	90	125	9.3	6
OOX-0940-900P61	9.4	36	90	125	9.4	6
OOX-0950-900P61	9.5	36	90	125	9.5	6
OOX-0960-900P61	9.6	36	90	125	9.6	6
OOX-0970-950P61	9.7	38	95	133	9.7	6
OOX-0980-950P61	9.8	38	95	133	9.8	6
OOX-0990-950P61	9.9	38	95	133	9.9	6
OOX-1000-950P61	10.0	38	95	133	10.0	6
OOX-1010-950P61	10.1	38	95	133	10.1	6
OOX-1020-950P61	10.2	38	95	133	10.2	6
OOX-1030-950P61	10.3	38	95	133	10.3	6
OOX-1040-950P61	10.4	38	95	133	10.4	6
OOX-1050-950P61	10.5	38	95	133	10.5	6
OOX-1060-950P61	10.6	38	95	133	10.6	6
OOX-1070-105P61	10.7	41	105	142	10.7	6
OOX-1080-105P61	10.8	41	105	142	10.8	6

Carbide Drill Bit

● Excellent ○ Good

Carbon Steels	Alloy Steels	Hardened Steels		High Hardened Steels	Copper	Cast iron	Aluminum	Stainless Steels	Titanium	Inconel
~HB225	HB225~325	HRC~50	HRC~55	HRC~60						
●	●						●	○		

CARBIDE REAMER O SERIES

(CONTINUATION)

STANDARD

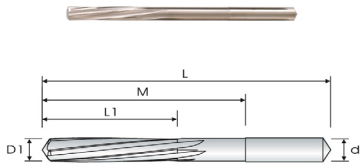

Part number	D1	L1	M	L	d	F
	Mill Dia.	Flute Length	Length under Shank	Overall Length	Shank Dia.	No. of Flute
OOX-1090-105P61	10.9	41	105	142	10.9	6
OOX-1100-105P61	11.0	41	105	142	11.0	6
OOX-1110-105P61	11.1	41	105	142	11.1	6
OOX-1120-105P61	11.2	41	105	142	11.2	6
OOX-1130-105P61	11.3	41	105	142	11.3	6
OOX-1140-105P61	11.4	41	105	142	11.4	6
OOX-1150-105P61	11.5	41	105	142	11.5	6
OOX-1160-105P61	11.6	41	105	142	11.6	6
OOX-1170-105P61	11.7	41	105	142	11.7	6
OOX-1180-105P61	11.8	41	105	142	11.8	6
OOX-1190-115P61	11.9	44	115	151	11.9	6
OOX-1200-115P61	12.0	44	115	151	12.0	6
OOX-1300-115P61	13.0	44	115	151	13.0	6

Carbide Drill Bit

● Excellent ○ Good

Carbon Steels	Alloy Steels	Hardened Steels		High Hardened Steels	Copper	Cast iron	Aluminum	Stainless Steels	Titanium	Inconel
~HB225	HB225~325	HRC~50	HRC~55	HRC~60						
●	●						●	○		

CARBIDE REAMER O SERIES

LONG SHANK

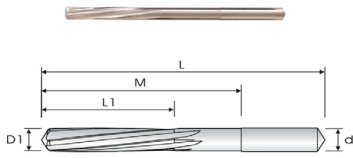

Part number	D1	L1	L	d	F
	Mill Dia.	Flute Length	Overall Length	Shank Dia.	No. of Flute
OOX-0300-150B41	3	15	100	3	4
OOX-0350-180P41	3.5	18	112	3.5	4
OOX-0400-190C61	4	19	119	4	6
OOX-0450-210P61	4.5	21	126	4.5	6
OOX-0500-230D61	5	23	132	5	6
OOX-0600-260E61	6	26	139	6	6
OOX-0700-310F61	7	31	156	7	6
OOX-0800-330G61	8	33	165	8	6
OOX-0900-360P61	9	36	175	9	6
OOX-1000-380H61	10	38	184	10	6
OOX-1100-410P61	11	41	195	11	6
OOX-1200-440I61	12	44	205	12	6
OOX-1300-440P61	13	44	205	13	6
OOX-1400-470P61	14	47	214	14	6
OOX-1500-500P61	15	50	220	15	6
OOX-1600-520J61	16	52	227	16	6
OOX-1700-540P61	17	54	235	17	6
OOX-1800-560P61	18	56	241	18	6
OOX-1900-580P61	19	58	247	19	6
OOX-2000-600K61	20	60	254	20	6

Carbide Drill Bit

● Excellent ○ Good

Carbon Steels	Alloy Steels	Hardened Steels		High Hardened Steels	Copper	Cast iron	Aluminum	Stainless Steels	Titanium	Inconel
~HB225	HB225~325	HRC~50	HRC~55	HRC~60						
●	●						●	○		

CARBIDE THREADING O SERIES

CARBIDE THREADING 60°



Part number	D1	Picrh	L1	L	d	F
	Mill Dia.		Reach Length	Overall Length	Shank Dia.	No. of Flute
OOX-0105-045B11	1.05	0.3	4.5	38	3	M1.4
OOX-0120-045B11	1.2	0.35	4.5	38	3	M1.6
OOX-0130-050B11	1.35	0.35	5.0	38	3	M1.8
OOX-0150-050B11	1.5	0.4	5.0	38	3	M2.0

Carbide Drill Bit

● Excellent ○ Good

Carbon Steels	Alloy Steels	Hardened Steels		High Hardened Steels	Copper	Cast iron	Aluminum	Stainless Steels	Titanium	Inconel
~HB225	HB225~325	HRc~50	HRc~55	HRc~60						
●	●	○								

CARBIDE T-SHAPE MILLING O SERIES

STRAIGHT FLUTE

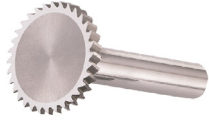

Part number	Outer Dia.	Cutter Thickness	d
			Shank Dia
OOT-1500-010F11	15	1.0	7
OOT-1500-015F11	15	1.5	7
OOT-1500-020F11	15	2.0	7
OOT-1500-025F11	15	2.5	7
OOT-1500-030F11	15	3.0	7
OOT-2000-010F11	20	1.0	7
OOT-2000-010H11	20	1.0	10
OOT-2000-015F11	20	1.5	7
OOT-2000-015H11	20	1.5	10
OOT-2000-020F11	20	2.0	7
OOT-2000-020H11	20	2.0	10
OOT-2000-025F11	20	2.5	7
OOT-2000-025H11	20	2.5	10
OOT-2000-030F11	20	3.0	7
OOT-2000-030H11	20	3.0	10
OOT-2500-010F11	25	1.0	7
OOT-2500-010H11	25	1.0	10
OOT-2500-015F11	25	1.5	7
OOT-2500-015H11	25	1.5	10
OOT-2500-020F11	25	2.0	7
OOT-2500-020H11	25	2.0	10
OOT-2500-025F11	25	2.5	7
OOT-2500-025H11	25	2.5	10
OOT-2500-030F11	25	3.0	7
OOT-2500-030H11	25	3.0	10
OOT-3000-010F11	30	1.0	7
OOT-3000-010H11	30	1.0	10
OOT-3000-015F11	30	1.5	7
OOT-3000-015H11	30	1.5	10
OOT-3000-020F11	30	2.0	7
OOT-3000-020H11	30	2.0	10
OOT-3000-025F11	30	2.5	7
OOT-3000-025H11	30	2.5	10
OOT-3000-030F11	30	3.0	7
OOT-3000-030H11	30	3.0	10

Carbide Drill Bit

● Excellent ○ Good

Carbon Steels	Alloy Steels	Hardened Steels		High Hardened Steels	Copper	Cast iron	Aluminum	Stainless Steels	Titanium	Inconel
~HB225	HB225~325	HRC~50	HRC~55	HRC~60						
●	●							●		

CARBIDE SHAPE MILLING O SERIES

HELIX FLUTE

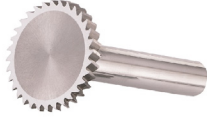

Part number	Outer Dia.	Cutter Thickness	d
			Shank Dia
OOX-1500-010F11	15	1	7
OOX-1500-015F11	15	1.5	7
OOX-1500-020F11	15	2	7
OOX-1500-025F11	15	2.5	7
OOX-1500-030F11	15	3	7
OOX-2000-010F11	20	1	7
OOX-2000-010H11	20	1	10
OOX-2000-015F11	20	1.5	7
OOX-2000-015H11	20	1.5	10
OOX-2000-020F11	20	2	7
OOX-2000-020H11	20	2	10
OOX-2000-025F11	20	2.5	7
OOX-2000-025H11	20	2.5	10
OOX-2000-030F11	20	3	7
OOX-2000-030H11	20	3	10
OOX-2500-010F11	25	1	7
OOX-2500-010H11	25	1	10
OOX-2500-015F11	25	1.5	7
OOX-2500-015H11	25	1.5	10
OOX-2500-020F11	25	2	7
OOX-2500-020H11	25	2	10
OOX-2500-025F11	25	2.5	7
OOX-2500-025H11	25	2.5	10
OOX-2500-030F11	25	3	7
OOX-2500-030H11	25	3	10
OOX-3000-010F11	30	1	7
OOX-3000-010H11	30	1	10
OOX-3000-015F11	30	1.5	7
OOX-3000-015H11	30	1.5	10
OOX-3000-020F11	30	2	7
OOX-3000-020H11	30	2	10
OOX-3000-025F11	30	2.5	7
OOX-3000-025H11	30	2.5	10
OOX-3000-030F11	30	3	7
OOX-3000-030H11	30	3	10

Carbide Drill Bit

● Excellent ○ Good

Carbon Steels	Alloy Steels	Hardened Steels		High Hardened Steels	Copper	Cast iron	Aluminum	Stainless Steels	Titanium	Inconel
~HB225	HB225~325	HRc~50	HRc~55	HRc~60						
●	●	○								

CARBIDE END MILL

O SERIES

SLIM SHANK

(Solid Type. Non-Brazed)

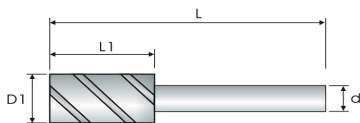

Part number	D1	L1	L	d	F
	Mill Dia.	Flute Length	Overall Length	Shank Dia.	No. of Flute
OOX-0500-125D21	5	12.5	50	5	2
OOX-0700-140F21	7	14	50	7	2
OOX-0800-150F21	8	15	45	7	2
OOX-1000-150F21	10	15	45	7	2
OOX-1000-150H21	10	15	45	10	2
OOX-1100-150F21	11	15	45	7	2
OOX-1100-150H21	11	15	45	10	2
OOX-1200-150F21	12	15	45	7	2
OOX-1200-150H21	12	15	45	10	2
OOX-1300-150H21	13	15	45	10	2
OOX-1400-150F21	14	15	45	7	2
OOX-1400-150H21	14	15	45	10	2
OOX-1500-150F21	15	15	45	7	2
OOX-1500-150H21	15	15	45	10	2
OOX-1600-150H21	16	15	45	10	2
OOX-1800-150H21	18	15	45	10	2
OOX-2000-150H21	20	15	45	10	2
OOX-0500-125D41	5	12.5	50	5	4
OOX-0700-140F41	7	14	50	7	4
OOX-0800-150F41	8	15	45	7	4
OOX-1000-150F41	10	15	45	7	4
OOX-1000-150H41	10	15	45	10	4
OOX-1100-150F41	11	15	45	7	4
OOX-1100-150H41	11	15	45	10	4
OOX-1200-150F41	12	15	45	7	4
OOX-1200-150H41	12	15	45	10	4
OOX-1300-150F41	13	15	45	7	4
OOX-1300-150H41	13	15	45	10	4
OOX-1400-150F41	14	15	45	7	4
OOX-1400-150H41	14	15	45	10	4
OOX-1500-150F41	15	15	45	7	4
OOX-1500-150H41	15	15	45	10	4
OOX-1600-150H41	16	15	45	10	4
OOX-1800-150H41	18	15	45	10	4
OOX-2000-150H41	20	15	45	10	4
OOX-2500-125H41	25	21	50	10	4

Carbide Drill Bit

● Excellent ○ Good

Carbon Steels	Alloy Steels	Hardened Steels		High Hardened Steels	Copper	Cast iron	Aluminum	Stainless Steels	Titanium	Inconel
~HB225	HB225~325	HRC~50	HRC~55	HRC~60						
●	●	●	●					●		

CARBIDE CIRCULAR SAW BLADE O SERIES

SMALL INNER DIAMETER

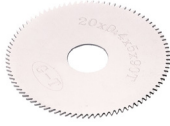

Part number	Outer Dia.	Inner Dia.	Thickness	Teeth
OOX-0150-015R11	15	5	0.15	72
OOX-0150-020R11	15	5	0.20	72
OOX-0150-025R11	15	5	0.25	72
OOX-0150-030R11	15	5	0.30	72
OOX-0150-040R11	15	5	0.40	72
OOX-0150-050R11	15	5	0.50	72
OOX-0150-060R11	15	5	0.60	48
OOX-0150-070R11	15	5	0.70	48
OOX-0150-080R11	15	5	0.80	48
OOX-0150-090R11	15	5	0.90	48
OOX-0150-100R11	15	5	1.00	48
OOX-0150-020R21	15	5	0.20	40
OOX-0150-025R21	15	5	0.25	40
OOX-0150-030R21	15	5	0.30	40
OOX-0150-040R21	15	5	0.40	40
OOX-0150-050R21	15	5	0.50	40
OOX-0150-060R21	15	5	0.60	40
OOX-0150-070R21	15	5	0.70	40
OOX-0150-080R21	15	5	0.80	40
OOX-0150-090R21	15	5	0.90	40
OOX-0150-100R21	15	5	1.00	40
OOX-0150-150Q11	15	5	1.50	36
OOX-0150-200Q11	15	5	2.00	36

Carbide Drill Bit

● Excellent ○ Good

Carbon Steels	Alloy Steels	Hardened Steels		High Hardened Steels	Copper	Cast iron	Aluminum	Stainless Steels	Titanium	Inconel
~HB225	HB225~325	HRC~50	HRC~55	HRC~60						
●	●							●		

CARBIDE CIRCULAR SAW BLADE

O SERIES

SMALL INNER DIAMETER



Part number	Outer Dia.	Inner Dia.	Thickness	Teeth
OOX-0200-015R11	20	5	0.15	90
OOX-0200-020R11	20	5	0.20	90
OOX-0200-025R11	20	5	0.25	90
OOX-0200-030R11	20	5	0.30	90
OOX-0200-040R11	20	5	0.40	90
OOX-0200-050R11	20	5	0.50	90
OOX-0200-015R21	20	5	0.15	56
OOX-0200-020R21	20	5	0.20	56
OOX-0200-025R21	20	5	0.25	56
OOX-0200-030R21	20	5	0.30	56
OOX-0200-040R21	20	5	0.40	56
OOX-0200-050R21	20	5	0.50	56
OOX-0200-060R11	20	5	0.60	56
OOX-0200-070R11	20	5	0.70	56
OOX-0200-080R11	20	5	0.80	56
OOX-0200-090R11	20	5	0.90	56
OOX-0200-100R11	20	5	1.00	56
OOX-0200-120R11	20	5	1.20	56
OOX-0200-150R11	20	5	1.50	56
OOX-0200-200R11	20	5	2.00	56
OOX-0200-230R11	20	5	2.30	56
OOX-0200-250R11	20	5	2.50	56
OOX-0200-300R11	20	5	3.00	56
OOX-0200-060R21	20	5	0.60	48
OOX-0200-070R21	20	5	0.70	48
OOX-0200-080R21	20	5	0.80	48
OOX-0200-090R21	20	5	0.90	48
OOX-0200-100R21	20	5	1.00	48
OOX-0200-120R21	20	5	1.20	36
OOX-0200-150R21	20	5	1.50	36
OOX-0200-200R21	20	5	2.00	36
OOX-0200-230R21	20	5	2.30	36
OOX-0200-250R21	20	5	2.50	36

Carbide Drill Bit

● Excellent ○ Good

Carbon Steels	Alloy Steels	Hardened Steels		High Hardened Steels	Copper	Cast iron	Aluminum	Stainless Steels	Titanium	Inconel
~HB225	HB225~325	HRC~50	HRC~55	HRC~60						
●	●							●		

CARBIDE CIRCULAR SAW BLADE O SERIES

SMALL INNER DIAMETER

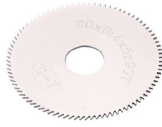

Part number	Outer Dia.	Inner Dia.	Thickness	Teeth
OOX-0060-015R11	20	6	0.15	90
OOX-0060-020R11	20	6	0.20	90
OOX-0060-025R11	20	6	0.25	90
OOX-0060-030R11	20	6	0.30	90
OOX-0060-040R11	20	6	0.40	90
OOX-0060-050R11	20	6	0.50	90
OOX-0060-020R21	20	6	0.20	56
OOX-0060-025R21	20	6	0.25	56
OOX-0060-030R21	20	6	0.30	56
OOX-0060-040R21	20	6	0.40	56
OOX-0060-050R21	20	6	0.50	56
OOX-0060-060R11	20	6	0.60	56
OOX-0060-070R11	20	6	0.70	56
OOX-0060-080R11	20	6	0.80	56
OOX-0060-090R11	20	6	0.90	56
OOX-0060-100R11	20	6	1.00	56
OOX-0060-120R11	20	6	1.20	56
OOX-0060-150R11	20	6	1.50	56
OOX-0060-200R11	20	6	2.00	56
OOX-0060-230R11	20	6	2.30	56
OOX-0060-250R11	20	6	2.50	56
OOX-0060-300R11	20	6	3.00	56
OOX-0060-060R21	20	6	0.60	48
OOX-0060-070R21	20	6	0.70	48
OOX-0060-080R21	20	6	0.80	48
OOX-0060-090R21	20	6	0.90	48
OOX-0060-100R21	20	6	1.00	48
OOX-0060-120R21	20	6	1.20	36
OOX-0060-150R21	20	6	1.50	36
OOX-0060-200R21	20	6	2.00	36
OOX-0060-230R21	20	6	2.30	36
OOX-0060-250R21	20	6	2.50	36

Carbide Drill Bit

● Excellent ○ Good

Carbon Steels	Alloy Steels	Hardened Steels		High Hardened Steels	Copper	Cast iron	Aluminum	Stainless Steels	Titanium	Inconel
~HB225	HB225~325	HRC~50	HRC~55	HRC~60						
●	●							●		

CARBIDE CIRCULAR SAW BLADE

O SERIES

SMALL INNER DIAMETER

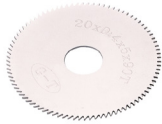

Part number	Outer Dia.	Inner Dia.	Thickness	Teeth
OOX-0250-015R11	25	6	0.15	120
OOX-0250-020R11	25	6	0.20	120
OOX-0250-025R11	25	6	0.25	120
OOX-0250-030R11	25	6	0.30	120
OOX-0250-040R11	25	6	0.40	120
OOX-0250-050R11	25	6	0.50	120
OOX-0250-015R21	25	6	0.15	72
OOX-0250-020R21	25	6	0.20	72
OOX-0250-025R21	25	6	0.25	72
OOX-0250-030R21	25	6	0.30	72
OOX-0250-040R21	25	6	0.40	72
OOX-0250-050R21	25	6	0.50	72
OOX-0250-060R11	25	6	0.60	72
OOX-0250-070R11	25	6	0.70	72
OOX-0250-080R11	25	6	0.80	72
OOX-0250-090R11	25	6	0.90	72
OOX-0250-100R11	25	6	1.00	72
OOX-0250-120R11	25	6	1.20	72
OOX-0250-150R11	25	6	1.50	72
OOX-0250-200R11	25	6	2.00	72
OOX-0250-230R11	25	6	2.30	72
OOX-0250-250R11	25	6	2.50	72
OOX-0250-280R11	25	6	2.80	72
OOX-0250-300R11	25	6	3.00	72
OOX-0250-060R21	25	6	0.60	56
OOX-0250-070R21	25	6	0.70	56
OOX-0250-080R21	25	6	0.80	56
OOX-0250-090R21	25	6	0.90	56
OOX-0250-100R21	25	6	1.00	56
OOX-0250-120R21	25	6	1.20	48
OOX-0250-150R21	25	6	1.50	48
OOX-0250-200R21	25	6	2.00	48
OOX-0250-230R21	25	6	2.30	48
OOX-0250-250R21	25	6	2.50	48
OOX-0250-280R21	25	6	2.80	48
OOX-0250-300R21	25	6	3.00	48

Carbide Drill Bit

● Excellent ○ Good

Carbon Steels	Alloy Steels	Hardened Steels		High Hardened Steels	Copper	Cast iron	Aluminum	Stainless Steels	Titanium	Inconel
~HB225	HB225~325	HRC~50	HRC~55	HRC~60						
●	●							●		

CARBIDE CIRCULAR SAW BLADE

O SERIES

SMALL INNER DIAMETER

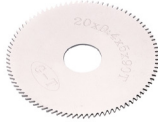

Part number	Outer Dia.	Inner Dia.	Thickness	Teeth
OOX-0300-020R11	30	6	0.20	120
OOX-0300-025R11	30	6	0.25	120
OOX-0300-030R11	30	6	0.30	120
OOX-0300-040R11	30	6	0.40	120
OOX-0300-050R11	30	6	0.50	120
OOX-0300-060R11	30	6	0.60	120
OOX-0300-070R11	30	6	0.70	120
OOX-0300-080R11	30	6	0.80	120
OOX-0300-090R11	30	6	0.90	120
OOX-0300-100R11	30	6	1.00	120
OOX-0300-120R11	30	6	1.20	120
OOX-0300-150R11	30	6	1.50	90
OOX-0300-200R11	30	6	2.00	90
OOX-0300-250R11	30	6	2.50	90
OOX-0300-300R11	30	6	3.00	90
OOX-0300-350R11	30	6	3.50	90
OOX-0300-400R11	30	6	4.00	90
OOX-0300-020R21	30	6	0.20	64
OOX-0300-025R21	30	6	0.25	64
OOX-0300-030R21	30	6	0.30	64
OOX-0300-040R21	30	6	0.40	64
OOX-0300-050R21	30	6	0.50	64
OOX-0300-060R21	30	6	0.60	64
OOX-0300-070R21	30	6	0.70	64
OOX-0300-080R21	30	6	0.80	64
OOX-0300-090R21	30	6	0.90	64
OOX-0300-100R21	30	6	1.00	64
OOX-0300-100R31	30	6	1.00	56
OOX-0300-120R21	30	6	1.20	56
OOX-0300-150R21	30	6	1.50	56
OOX-0300-200R21	30	6	2.00	56
OOX-0300-230R21	30	6	2.30	56
OOX-0300-250R21	30	6	2.50	56
OOX-0300-300R21	30	6	3.00	56
OOX-0300-350R21	30	6	3.50	56
OOX-0300-400R21	30	6	4.00	56

Carbide Drill Bit

● Excellent ○ Good

Carbon Steels	Alloy Steels	Hardened Steels		High Hardened Steels	Copper	Cast iron	Aluminum	Stainless Steels	Titanium	Inconel
~HB225	HB225~325	HRc~50	HRc~55	HRc~60						
●	●							●		

CARBIDE CIRCULAR SAW BLADE

O SERIES

SMALL INNER DIAMETER



Part number	Outer Dia.	Inner Dia.	Thickness	Teeth
OOX-0450-020Q11	45	12.7	0.20	90
OOX-0450-025Q11	45	12.7	0.25	90
OOX-0450-030Q11	45	12.7	0.30	90
OOX-0450-040Q11	45	12.7	0.40	90
OOX-0450-050Q11	45	12.7	0.50	90
OOX-0450-060Q11	45	12.7	0.60	90
OOX-0450-070Q11	45	12.7	0.70	90
OOX-0450-080Q11	45	12.7	0.80	90
OOX-0450-090Q11	45	12.7	0.90	90
OOX-0450-100Q11	45	12.7	1.00	90
OOX-0450-150Q11	45	12.7	1.50	90
OOX-0450-200Q11	45	12.7	2.00	90
OOX-0450-250Q11	45	12.7	2.50	72
OOX-0450-300Q11	45	12.7	3.00	72

Carbide Drill Bit

● Excellent ○ Good

Carbon Steels	Alloy Steels	Hardened Steels		High Hardened Steels	Copper	Cast iron	Aluminum	Stainless Steels	Titanium	Inconel
~HB225	HB225~325	HRC~50	HRC~55	HRC~60						
●	●							●		

CARBIDE CIRCULAR SAW BLADE O SERIES

FOR BERYLLIUM COPPER

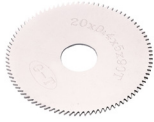

Part number	Outer Dia.	Inner Dia.	Thickness	Teeth
OOX-0015-080R11	20	5	0.15	80
OOX-0020-080R11	20	5	0.20	80
OOX-0025-080R11	20	5	0.25	80
OOX-0030-080R11	20	5	0.30	80
OOX-0035-080R11	20	5	0.35	80
OOX-0040-080R11	20	5	0.40	80
OOX-0015-080R21	20	6	0.15	80
OOX-0020-080R21	20	6	0.20	80
OOX-0025-080R21	20	6	0.25	80
OOX-0030-080R21	20	6	0.30	80
OOX-0035-080R21	20	6	0.35	80
OOX-0040-080R21	20	6	0.40	80
OOX-0015-080R31	25	6	0.15	80
OOX-0020-080R31	25	6	0.20	80
OOX-0025-080R31	25	6	0.25	80
OOX-0030-080R31	25	6	0.30	80
OOX-0035-080R31	25	6	0.35	80
OOX-0040-080R31	25	6	0.40	80

Carbide Drill Bit

● Excellent ○ Good

Carbon Steels	Alloy Steels	Hardened Steels		High Hardened Steels	Copper	Cast iron	Aluminum	Stainless Steels	Titanium	Inconel
		HRc~50	HRc~55	HRc~60						
~HB225	HB225~325							●		

SAW BLADE



Part number	Inner Dia. of Saw Blade	SD	SL	No. of Washer (Max.)	Dia. of Washer	A	B	C	D	E	F	G
		Shank Dia.	Overall Length									
OOX-0500-047D11	5	5	47	3	6.9	9	6	5.9	5.9	5.3	φ6.9	M5
OOX-0700-051R11	5	7	51	3	9.9	9	6.9	7	7.8	7.2	φ10	M5
OOX-1000-051H11	5	10	51	3	9.9	9	6.9	7	7.8	7.2	φ10	M5
OOX-0700-051R21	6	7	51	3	9.9	11.3	6.5	6.9	7.9	7.1	φ10	M6
OOX-1000-058H11	6	10	58	3	9.9	11.3	7.5	7	8	6.1	φ10	M6
OOX-0600-052E11	8	6	52	3	12.9	13.3	7	7.7	11.9	7.5	φ13	M8
OOX-0700-052F11	8	7	52	3	12.9	13.3	7	7.7	11.9	7.5	φ13	M8
OOX-1000-052H11	8	10	52	3	12.9	13.3	7	7.7	11.9	7.5	φ13	M8
OOX-1000-057H11	12.7	10	57	3	19.9	21.7	7.6	10	16.9	9.1	φ19.6	1/2-20UNF

COMBO



Part number	Inner Dia. of Saw Blade	d	L	Dia. of Drill Shank	No. of Washer (Max.)
		Shank Dia.	Overall Length		
OOX-0700-051R11	5	7	51	3	3
OOX-0700-051R21	6	7	51	3	3